



Ultra light caliper

ACCESSORIES



		UL4	UL H4	ULV4	UL D4
811-2321	Lower plate for internal anvil (2 pieces) (for Bowers Unical's «L anvils»)	●	●		
811-2322	Lower internal anvil (2 pieces)	●	●		
811-2323	Upper internal measurement anvil (2 pieces)* (to combine with 811.2303)	●	●		
811-2324	Long cylindrical anvil Ø8x80mm (2 pieces) (to combine with 811-2302 & 811-2301)	●	●		
811-2325	Cylindrical anvil Ø8x30mm (2 pieces)	●	●		

APPLICATIONS



Internal measure with UL4

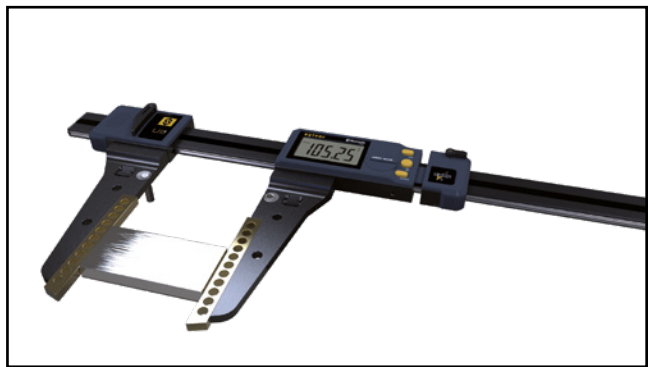

External measure with UL4



MICROMETERS

Historically, the micrometric screw was invented by William Gascoigne in the 17th century and it was Jean-Laurent Palmer who applied the principle to the measurement of small distances in 1848. Another classic length-measuring instrument, the micrometer provides greater precision than the caliper. Whereas a drum lathe generally represents a spindle displacement of 0.5 mm, Sylvac had the brilliant idea of developing revolutionary fast-feed micrometers in various versions, which can be discovered in this chapter.

GENERAL CHARACTERISTICS :

- **Accuracy according to DIN 863**
- **Powered by lithium battery type CR2032**
- **Absolute measuring system S.I.S**
- **Automatic sleep and wake-up**
- **mm/inch conversion on all models**
- **Working temperature +5° to +40°C**



Professional micrometer

S_Mike PRO

DESCRIPTION

CYLINDRICAL Ø6.5

- High-speed micrometer with non-rotating spindle
- Linear spindle feed 10 mm per revolution
- Measuring range greater than traditional micrometers
- Tungsten carbide measuring anvils Ø 6.5 mm
- Display resolution 0.001 mm
- Ratchet system cancels operator influence and guarantees excellent repeatability
- Switchable measuring force 5 or 10 N for the 0-30 mm model
- Proximity data output
- Measuring range up to 161 mm
- Protection class IP67

D

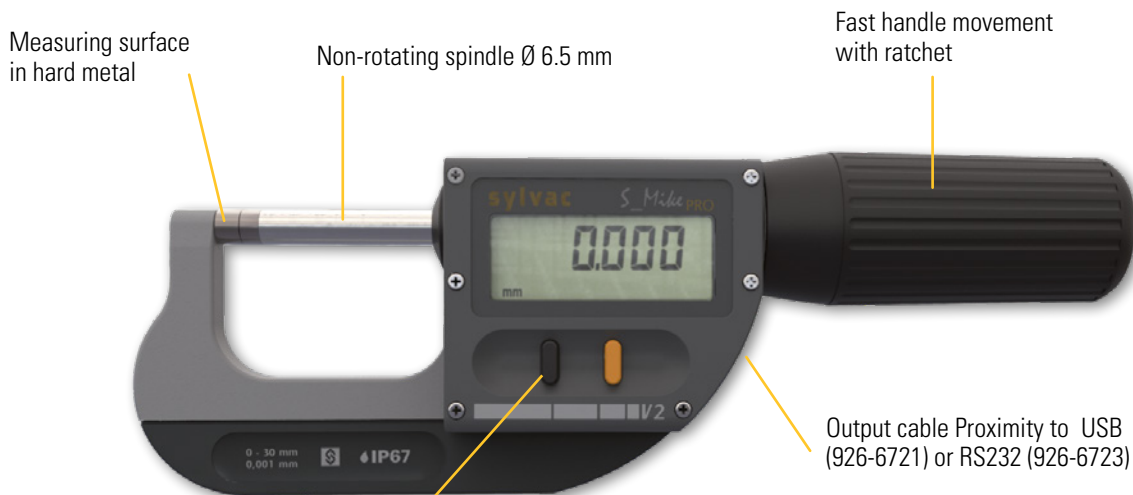

Simple and friendly functions



DIN 863

PROXIMITY

SIS Smart Inductive System

WATER RESISTANT

IP67

SWISS MADE

* SIS description on page 5

Professional micrometer

S_Mike PRO

DIMENSIONAL DRAWING

CYLINDRICAL Ø6.5

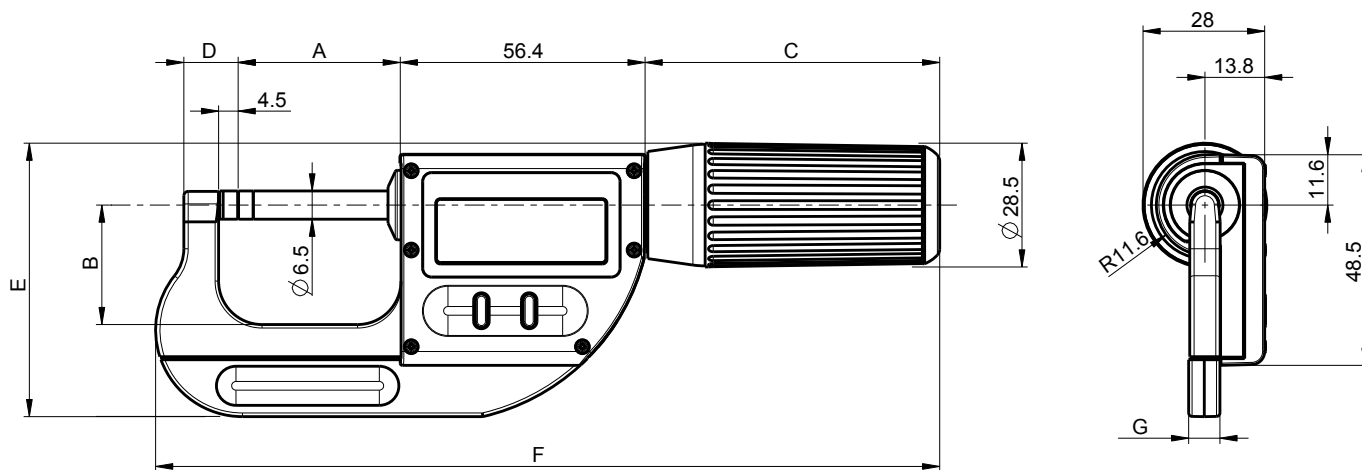

TECHNICAL SPECIFICATIONS

		803-0300	903-0600	903-1000	903-1360	903-1600
Measuring range	mm	0-30	30-66	66-102	100-136	125-161
Max. Error G ¹⁾	µm	3	4	5	7	8
Repeatability ²⁾	µm	1	1	1	2	2
Anvils types		Ø6.5				
A	mm	37.3	73.3	109.3	143.3	168.3
B	mm	27.5	43	60	95	110
C	mm	68	74	74	74	74
D	mm	12.5	13.5	14.5	19.5	19.5
E	mm	63	86	106	151	169
F	mm	181	230	269	306	339
G	mm	7.2	9	9	9	9
Output data		USB / RS 232 ³⁾				
Prot. rating accor. to IEC 60529		IP67 even connected				
Setting by PC		●				
Adjustable measuring force		5N / 10N		10N		
Non-rotating spindle		●				
Fast movement		●				
Preset function		●				
Smart Inductive Sensor		●				

¹⁾ according to DIN 863

²⁾ ± 1 digit

³⁾ see cables chapter

Professional micrometer

S_Mike PRO Smart

DESCRIPTION

CYLINDRICAL Ø6.5 SMART

- Ultra-fast non-rotating spindle micrometer with integrated Bluetooth® system
- Linear spindle feed 10 mm per revolution
- Measuring range greater than traditional micrometers
- Tungsten carbide measuring anvils Ø 6.5 mm
- Display resolution 0.001 mm
- Ratchet system cancels operator influence and guarantees excellent repeatability
- Switchable measuring force 5 or 10 N for the 0-30 mm model
- Measuring range up to 102 mm (161 mm on request)
- Protection class IP67

D

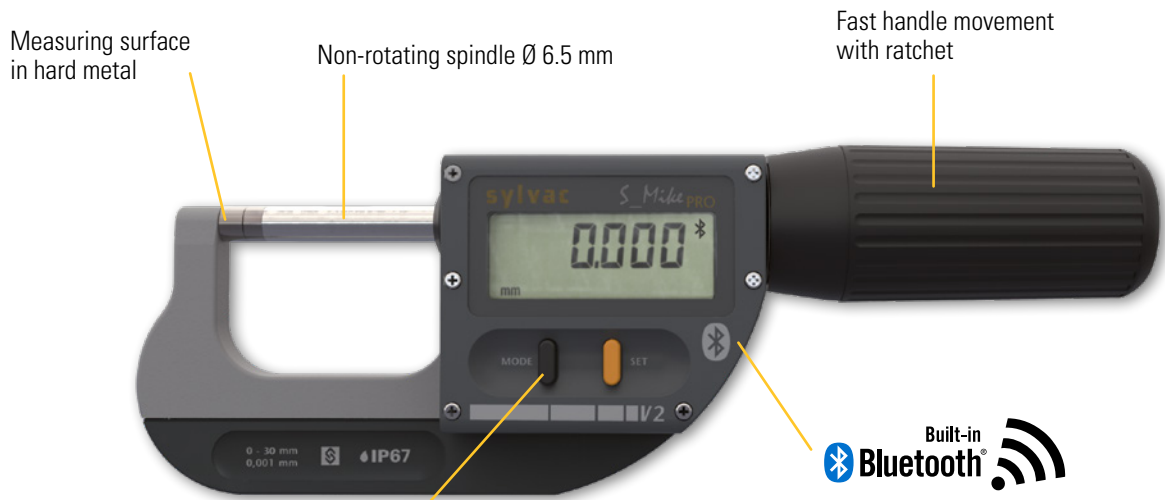

DIN 863

Built-in **Bluetooth**

SIS Smart Inductive System

WATER RESISTANT

IP67

SWISS MADE

Simple and friendly functions

Cylindrical Ø6.5mm



* SIS description on page 5



Professional micrometer

S_Mike PRO Smart

DIMENSIONAL DRAWING

CYLINDRICAL Ø6.5 SMART

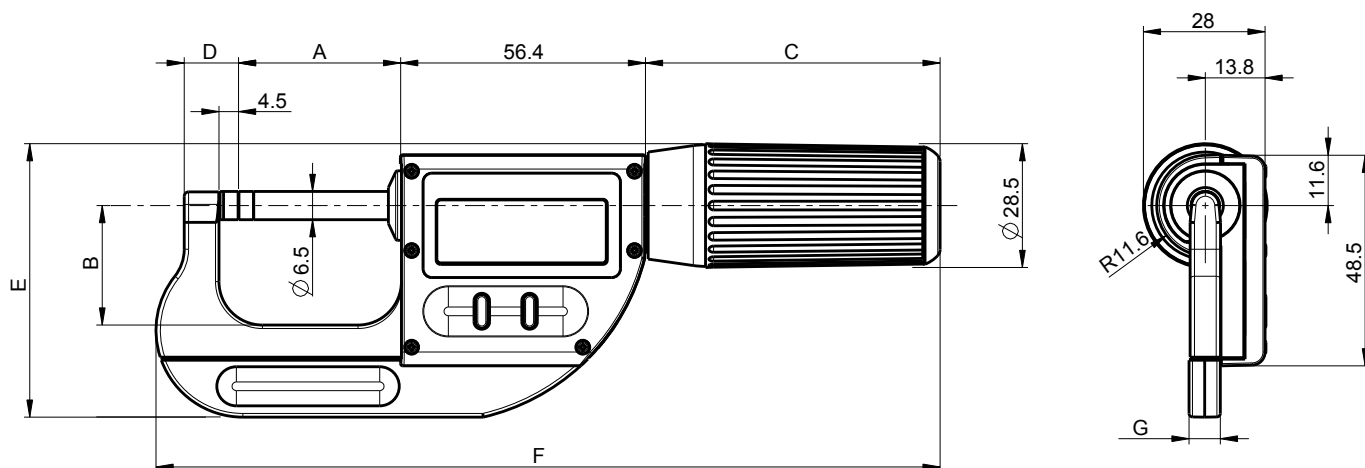

TECHNICAL SPECIFICATIONS

		803-0306	903-0606	903-1006
Measuring range	mm	0-30	30-66	66-102
Max. Error G ¹⁾	µm	3	4	5
Repeatability ²⁾	µm	1	1	1
Anvils types		Ø6.5 ³⁾		
A	mm	37.3	73.3	109.3
B	mm	27.5	43	60
C	mm	68	74	74
D	mm	12.5	13.5	14.5
E	mm	63	86	106
F	mm	181	230	269
G	mm	7.2	9	9
Output data	Bluetooth® wireless technology*			
Prot. rating accor. to IEC 60529	IP67 even connected			
Setting by PC	●			
Adjustable measuring force	5N / 10N	10N		
Non-rotating spindle	●			
Fast movement	●			
Preset function	●			
Smart Inductive Sensor	●			

¹⁾ according to DIN 863

²⁾ ± 1 digit

³⁾ Other anvils type on demand.

*** Up to 8 instruments connected per dongle #981-7100**

Professional micrometer

S_Mike PRO

DESCRIPTION

CYLINDRICAL Ø2

- High-speed micrometer with non-rotating spindle with or without integrated Bluetooth® system
- Linear spindle feed 10 mm per revolution
- Tungsten carbide measuring anvils Ø 2 x 5 mm
- Possibility to obtain this micrometer with different diameter keys (more than 2 mm) on request.
- Display resolution 0.001 mm
- Ratchet system cancels operator influence and guarantees excellent repeatability
- Switchable measuring force 5 or 10 N for the 0-25 mm model
- Proximity data output for non-Bluetooth models
- All models are available in Bluetooth version on request.
- Measuring range up to 95 mm
- Protection class IP67

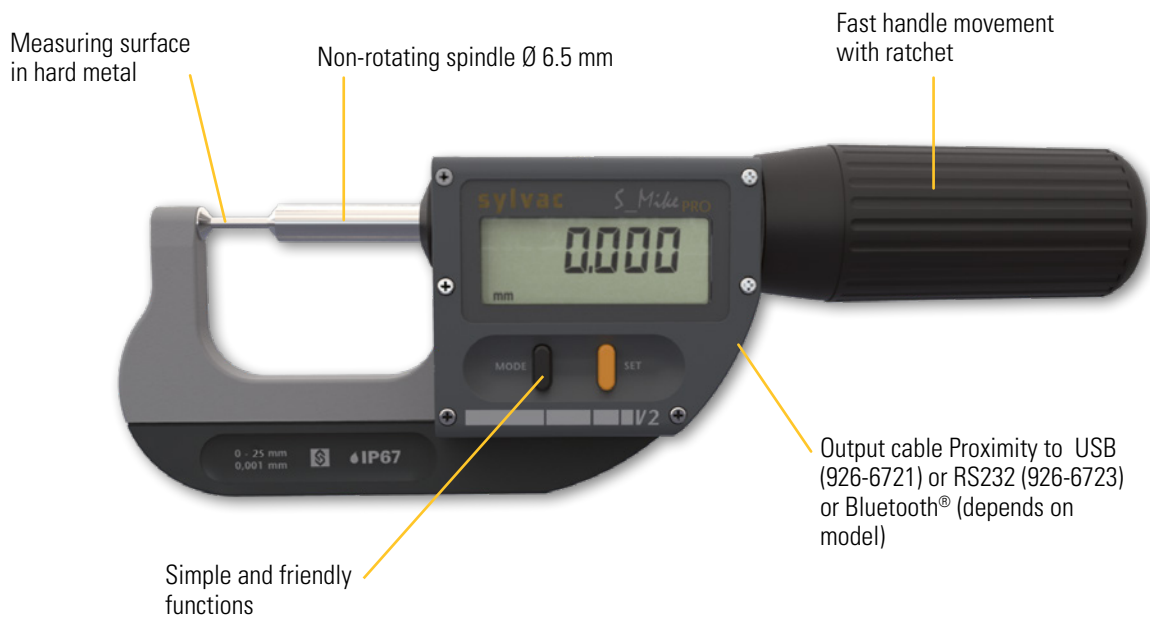

DIN 863



SIS Smart Inductive System



IP67

SWISS MADE

Cylindrical Ø2mm



* SIS description on page 5



Professional micrometer

S_Mike PRO

DIMENSIONAL DRAWING

CYLINDRICAL Ø2

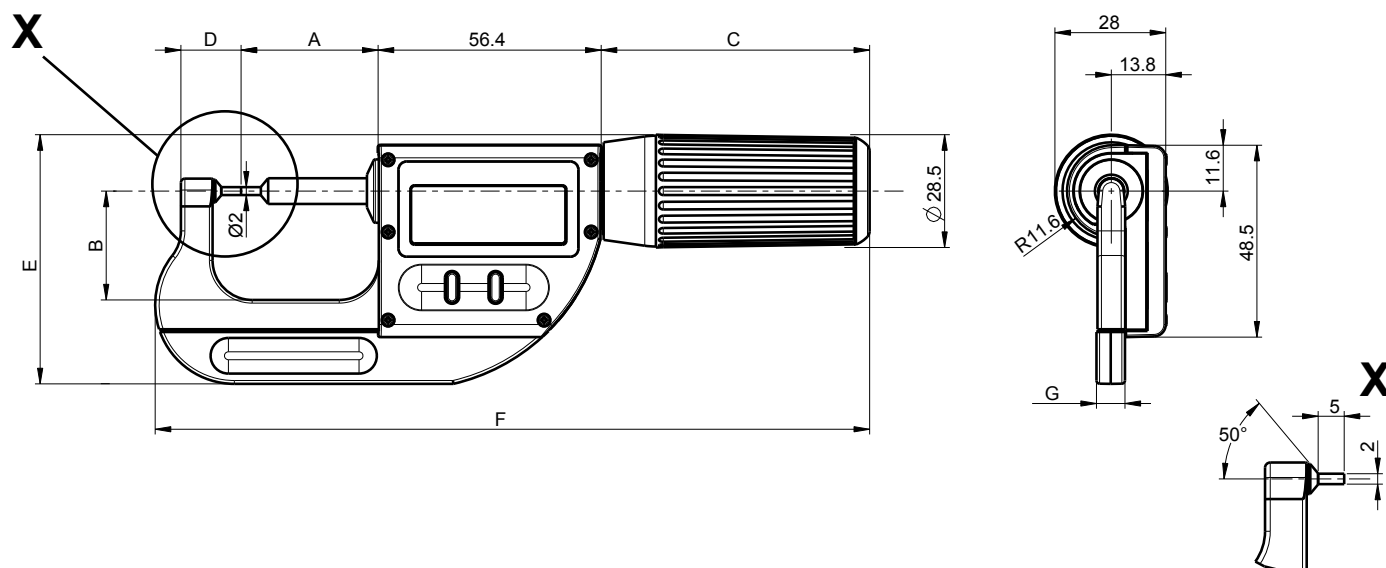

TECHNICAL SPECIFICATIONS

		803-0301	903-0601	903-1001	803-0307
Measuring range	mm	0-25	25-60	60-95	0-25
Max. Error G ¹⁾	µm	3	4	5	3
Repeatability ²⁾	µm	1	1	1	1
Anvils types			Ø2		Ø2
A	mm	34.6	70.6	106.6	34.6
B	mm	27.5	43	60	27.5
C	mm	68	74	74	68
D	mm	15.2	16.2	17.2	15.2
E	mm	63	86	106	63
F	mm	181	230	269	181
G	mm	7.2	9	9	7.2
Output data		USB / RS 232 ³⁾			Bluetooth*
Prot. rating accor. to IEC 60529		IP67 even connected			
Setting by PC			●		
Adjustable measuring force		5N / 10N		10N	5N / 10N
Non-rotating spindle			●		
Fast movement			●		
Preset function			●		
Smart Inductive Sensor			●		

¹⁾ according to DIN 863

²⁾ ± 1 digit

³⁾ see cables chapter

* Up to 8 instruments connected per dongle #981-7100

Professional micrometer

S_Mike PRO

DESCRIPTION

KNIFE-SHAPED

- High-speed micrometer with non-rotating spindle with or without integrated Bluetooth® system
- Linear spindle feed 10 mm per revolution
- Tungsten carbide measuring anvils, knife type, thickness 0.75 x 6.5 mm
- Possibility to obtain this micrometer with anvils of different thickness (minimum 0.4 mm) on request.
- Display resolution 0.001 mm
- Ratchet system cancels operator influence and guarantees excellent repeatability
- Switchable measuring force 5 or 10 N for the 0-25 mm model
- Proximity data output for non-Bluetooth® models
- All models are available in Bluetooth® version on request.
- Measuring range up to 95 mm
- Protection class IP67

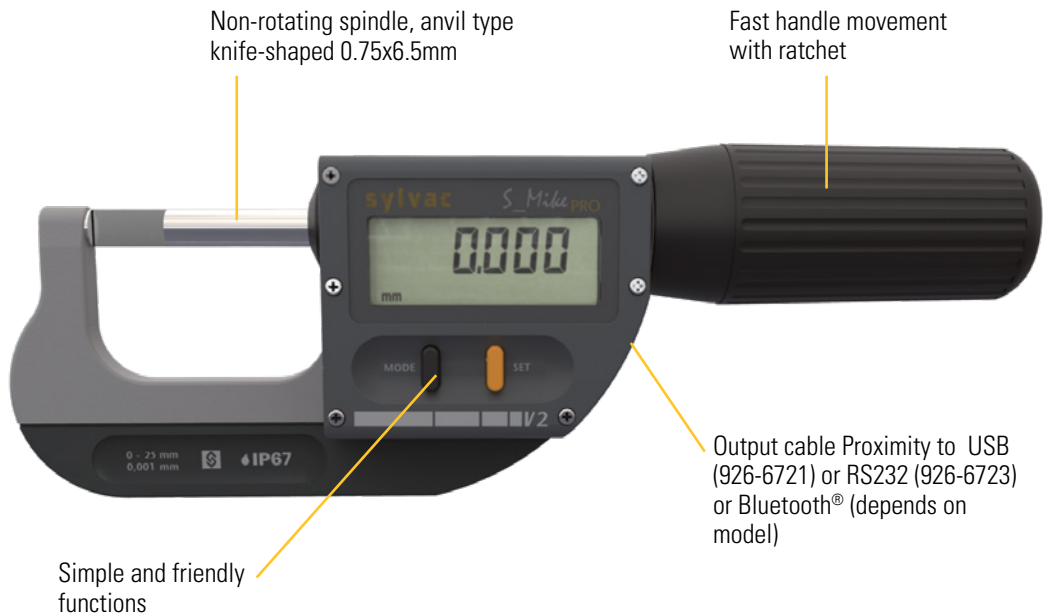

DIN 863



SIS Smart Inductive System



IP67

SWISS MADE

Knife-shaped



* SIS description on page 5



Professional micrometer

S_Mike PRO

DIMENSIONAL DRAWING

KNIFE-SHAPED

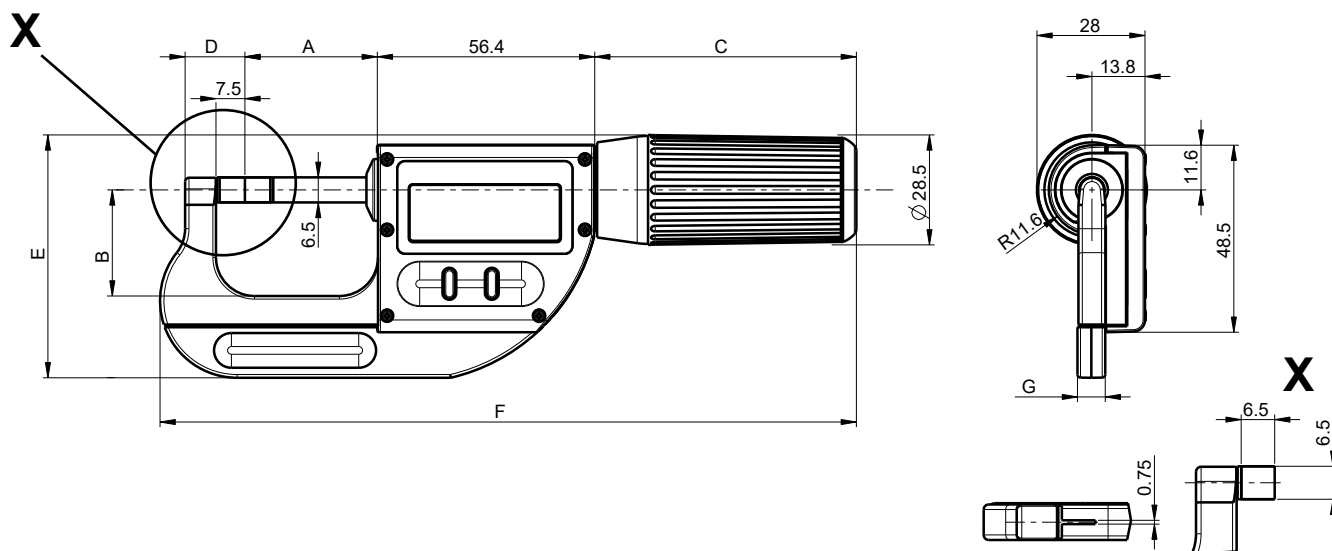

TECHNICAL SPECIFICATIONS

		803-0302	903-0602	903-1002	903-1302	903-1602	803-0308
Measuring range	mm	0-25	25-60	60-95	95-130	120-155	0-25
Max. Error G ¹⁾	µm	3	4	5	6	7	3
Repeatability ²⁾	µm	1	1	1	2	2	1
Anvils types		0.75x6.5					0.75x6.5
A	mm	34.3	70.3	106.3	140.3	165.3	34.3
B	mm	27.5	43	60	95	110	27.5
C	mm	68	74	74	74	74	68
D	mm	15.5	16.5	17.5	22.5	22.5	15.5
E	mm	63	86	106	151	169	63
F	mm	181	230	269	306	339	181
G	mm	7.2	9	9	9	9	7.2
Output data		USB / RS 232 ³⁾					Bluetooth*
Prot. rating accor. to IEC 60529		IP67 even connected					
Setting by PC		●					
Adjustable measuring force		5N / 10N	10N				5N / 10N
Non-rotating spindle		●					
Fast movement		●					
Preset function		●					
Smart Inductive Sensor		●					

¹⁾ according to DIN 863

²⁾ ± 1 digit

³⁾ see cables chapter

*** Up to 8 instruments connected per dongle #981-7100**

Professional micrometer

S_Mike PRO

DESCRIPTION

DISC-SHAPED

- High-speed micrometer with non-rotating spindle
- Linear spindle feed 10 mm per revolution
- Tungsten carbide measuring discs Ø 25 mm
- For technical reasons, this micrometer cannot be delivered with different discs.
- Display resolution 0.001 mm
- Ratchet system cancels operator influence and guarantees excellent repeatability
- Switchable measuring force 5N
- Bluetooth® data output (Proximity data output for non-Bluetooth® models)
- Measuring range limited to 102 mm
- Protection class IP67

D

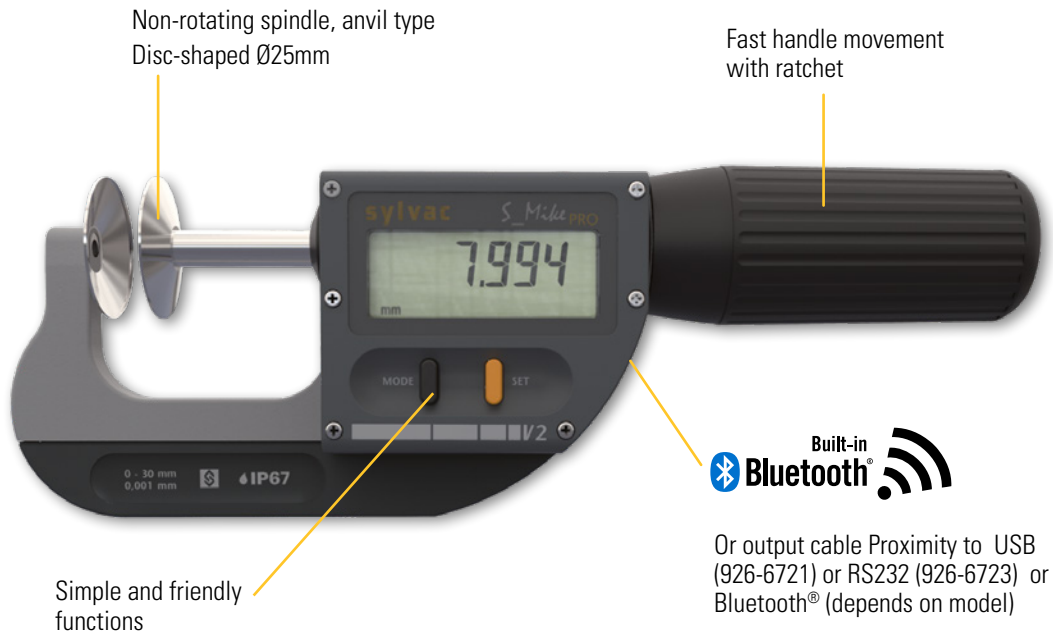

DIN 863

SIS Smart Inductive System

WATER RESISTANT

IP67

SWISS MADE

Disc-shaped

* SIS description on page 5



Professional micrometer

S_Mike PRO

DIMENSIONAL DRAWING

DISC-SHAPED

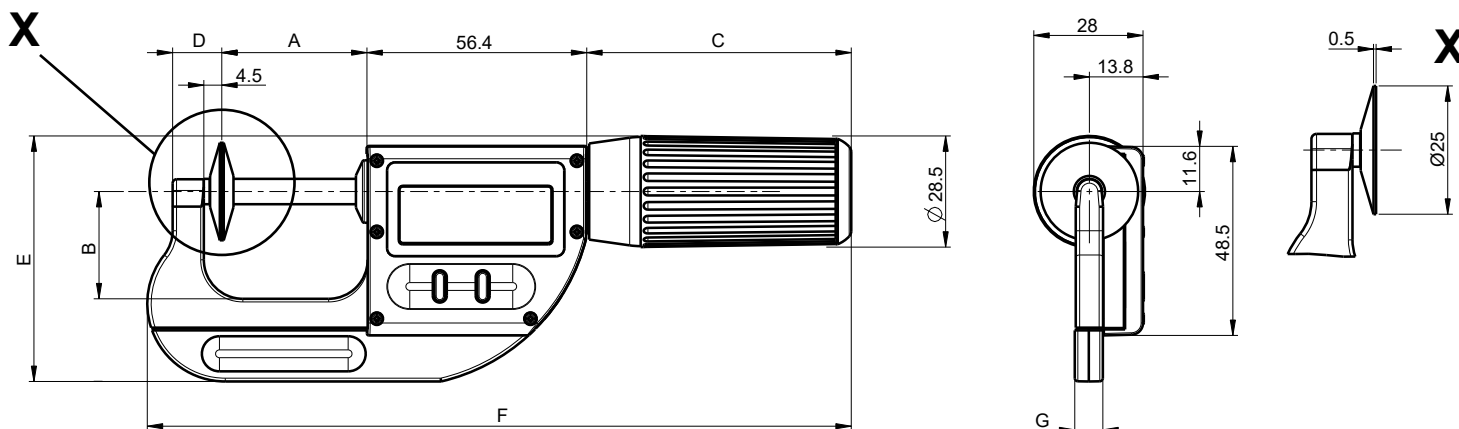

TECHNICAL SPECIFICATIONS

		803-0303	803-0313	903-0613	903-1013
Measuring range	mm	0-30	0-30	30-66	66-102
Max. Error G ¹⁾	µm	4 (full-touch-contact) / 10 (partial contact)		5 (full-touch-contact) / 11 (partial contact)	6 (full-touch-contact) / 12 (partial contact)
Repeatability ²⁾	µm	1			
Flatness	µm	2			
Parallelism	µm	5 (full-touch-contact) / 10 (partial contact)		6 (full-touch-contact) / 12 (partial contact)	6 (full-touch-contact) / 12 (partial contact)
Gear unit		Measurable module ≥ 0.5			
Anvils types		Ø25			
Output data		USB / RS 232 ³⁾	Bluetooth® wireless technology*		
Prot. rating accor. to IEC 60529		IP67 even connected			
A		37.3	37.3	73.3	109.3
B		27.5	27.5	43	60
C		68	68	74	74
D		12.5	12.5	13.5	14.5
E		63	63	86	106
F		181	181	230	269
G		7.2	7.2	9	9
Setting by PC		●			
Measuring force		5N			
Non-rotating spindle		●			
Fast movement		●			
Preset function		●			
Smart Inductive Sensor		●			

¹⁾ according to DIN 863 / ²⁾ ± 1 digit / ³⁾ see cables chapter

* Up to 8 instruments connected per dongle #981-7100

Professional micrometer

S_Mike PRO

DESCRIPTION

FLAT Ø6.5 / SPHERICAL Ø7

- High-speed micrometer with non-rotating spindle
- Linear spindle feed 10 mm per revolution
- Tungsten-carbide measuring anvils with a fixed Ø 7 mm ball probe on the fixed side and a flat Ø 6.5 mm probe on the movable side.
- For technical reasons, this micrometer cannot be delivered with different anvils.
- Display resolution 0.001 mm
- Ratchet system cancels operator influence and guarantees excellent repeatability
- Switchable measuring force 5 or 10 N
- Proximity data output
- This model is available in Bluetooth® version on request.
- Measuring range limited to 30 mm
- Protection class IP67

D

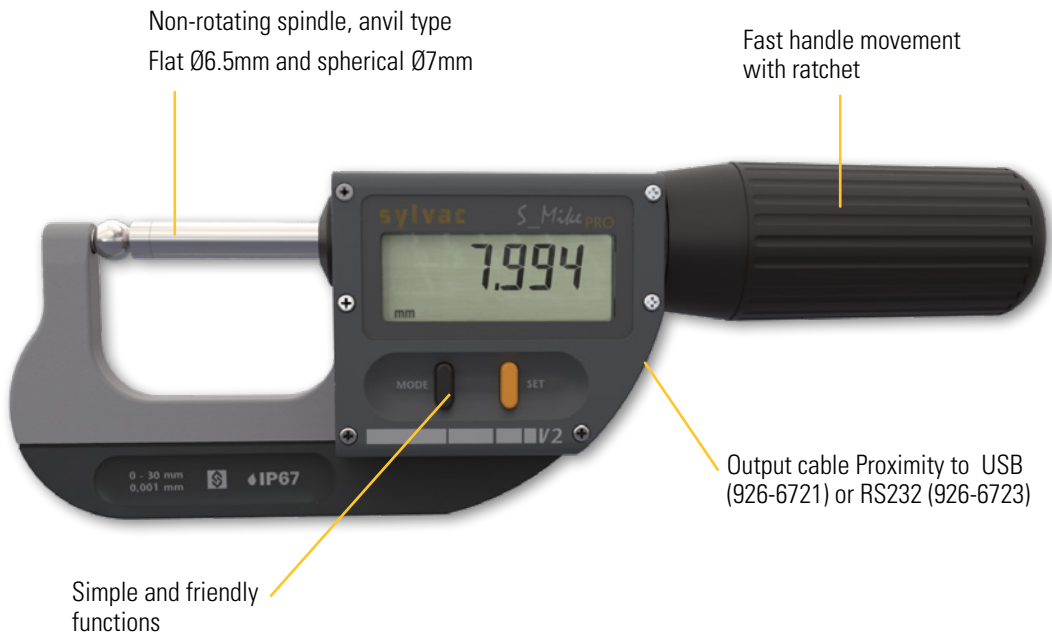

DIN 863

PROXIMITY

SIS Smart Inductive System

WATER RESISTANT

IP67

SWISS MADE

Flat Ø6.5mm / Spherical Ø7mm

* SIS description on page 5



Professional micrometer

S_Mike PRO

DIMENSIONAL DRAWING

FLAT Ø6.5 / SPHERICAL Ø7

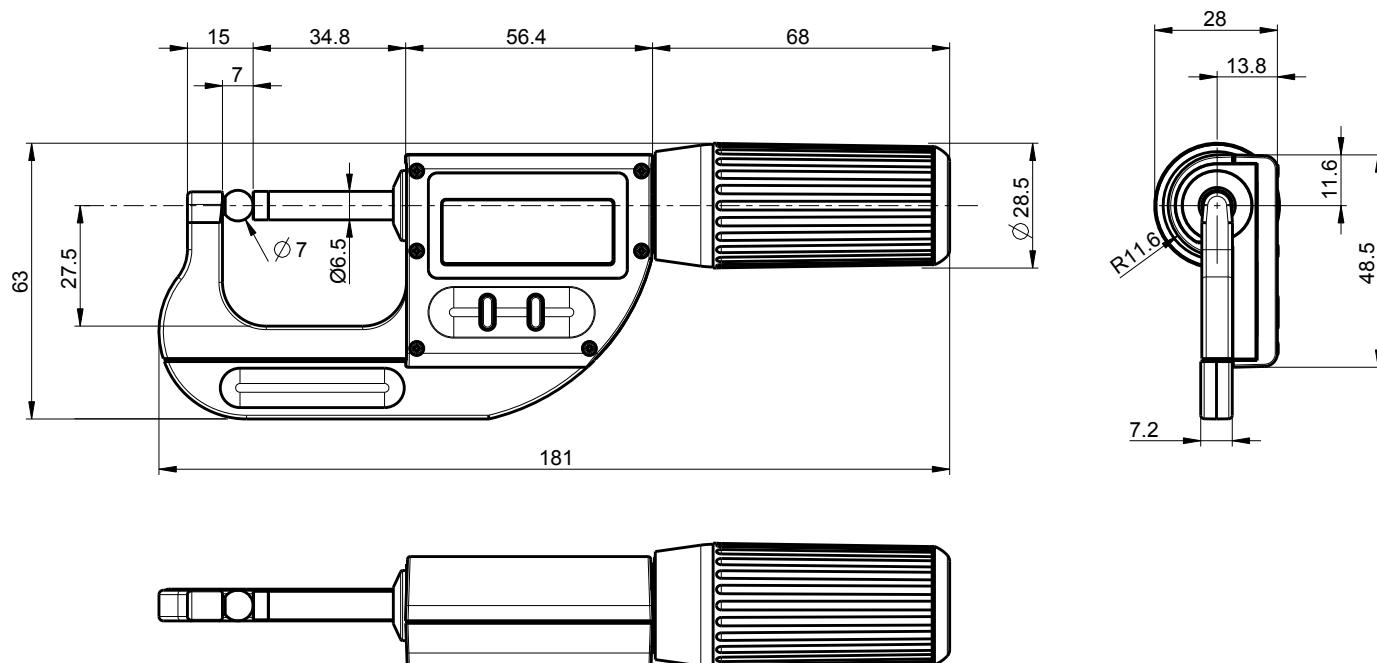

D

TECHNICAL SPECIFICATIONS

		803.0304
Measuring range	mm	0-30
Max. Error G ¹⁾	µm	3
Repeatability ²⁾	µm	1
Parallelism	µm	1
Anvils types		Ø7 flat and Ø7 spherical
Output data		USB / RS 232 / Wireless ³⁾
Prot. rating accor. to IEC 60529		IP67 even connected
Setting by PC		●
Adjustable measuring force		5N / 10N
Non-rotating spindle		●
Fast movement		●
Preset function		●
Smart Inductive Sensor		●

¹⁾ according to DIN 863

²⁾ ± 1 digit

³⁾ see cables chapter

Professional micrometer

S_Mike PRO

DESCRIPTION

SPHERICAL Ø7

- High-speed micrometer with non-rotating spindle
- Linear spindle feed 10 mm per revolution
- Tungsten-carbide measuring anvils with fixed side a complete sphere Ø 7 mm and movable side a spherical probe with a radius of 3.5 mm
- For technical reasons, this micrometer cannot be delivered with different anvils.
- Display resolution 0.001 mm
- Ratchet system cancels operator influence and guarantees excellent repeatability
- Switchable measuring force 5 or 10 N
- Proximity data output
- This model is available in Bluetooth® version on request.
- Measuring range limited to 30 mm
- Protection class IP67

D

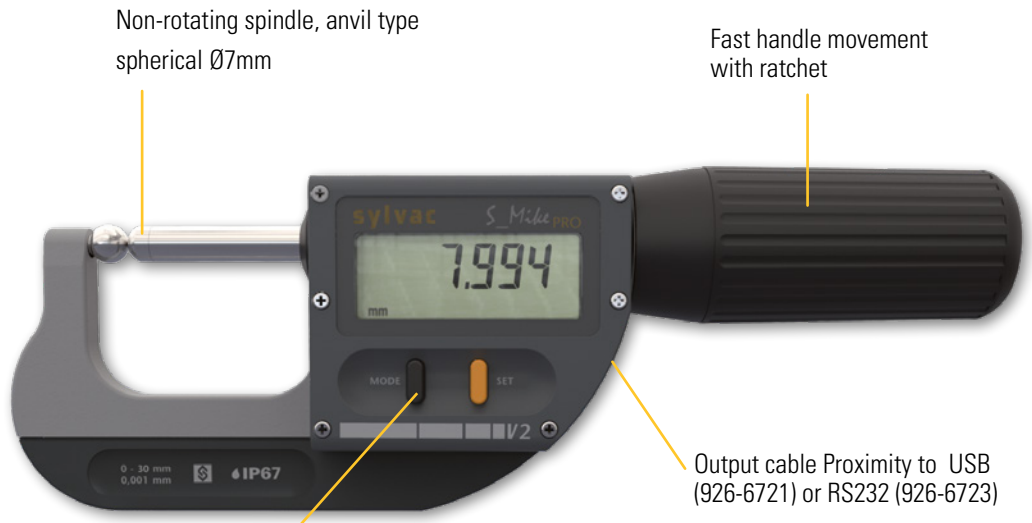

DIN 863

PROXIMITY

SIS Smart Inductive System

WATER RESISTANT

IP67

SWISS MADE

Simple and friendly functions

Spherical Ø7mm

* SIS description on page 5

Professional micrometer

S_Mike PRO

DIMENSIONAL DRAWING

SPHERICAL Ø7

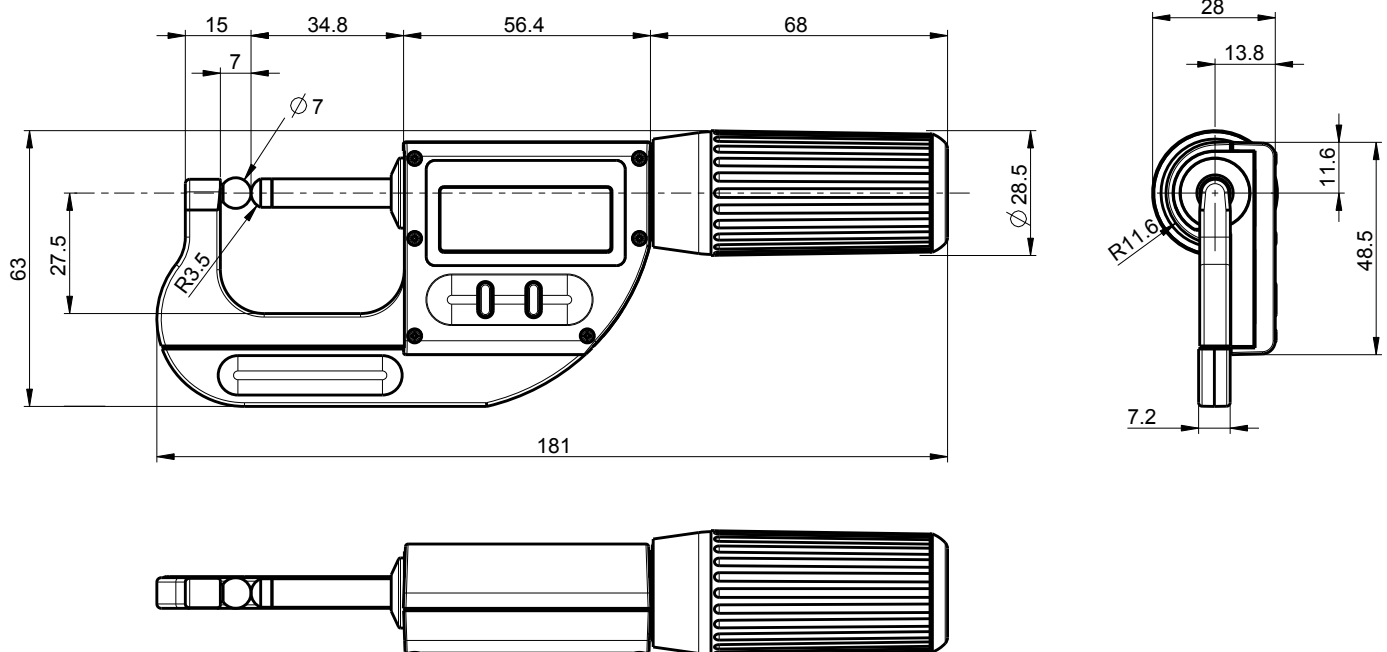

D

TECHNICAL SPECIFICATIONS

		803.0305
Measuring range	mm	0-30
Max. Error G ¹⁾	µm	4
Repeatability ²⁾	µm	1
Anvils types		Ø7 (2 spherical)
Output data		USB / RS 232 / Wireless ³⁾
Prot. rating accor. to IEC 60529		IP67 even connected
Setting by PC		●
Adjustable measuring force		5N / 10N
Non-rotating spindle		●
Fast movement		●
Preset function		●
Smart Inductive Sensor		●

¹⁾ according to DIN 863

²⁾ ± 1 digit

³⁾ see cables chapter

Professional micrometer

S_Mike PRO

DESCRIPTION

KNIFE-SHAPED / CONE

- High-speed micrometer with non-rotating spindle and integrated Bluetooth® system
- Linear spindle feed 10 mm per revolution
- Special instrument for checking the crimping of electrical cables
- Tungsten-carbide measuring anvils with fixed anvil side, one knife anvil 0.5 x 6.6 mm thick and movable anvil side, one conical anvil 5.2 mm wide.
- For technical reasons, this micrometer cannot be delivered with different anvils.
- Display resolution 0.001 mm
- Ratchet system cancels operator influence and guarantees excellent repeatability
- Switchable measuring force 5 or 10 N
- Measuring range limited to 25 mm
- Protection class IP67

D

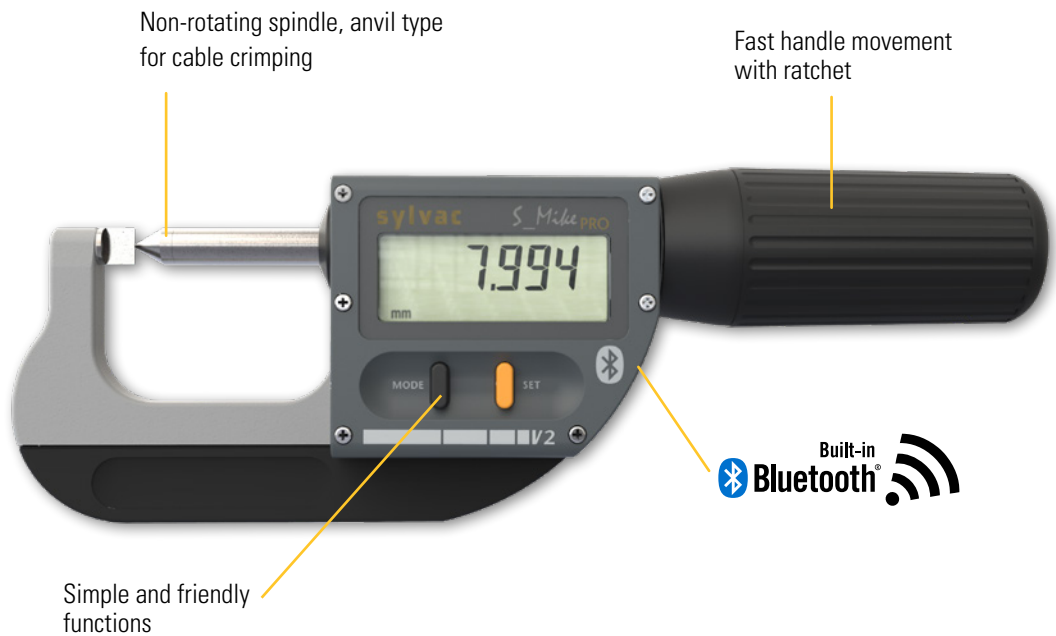

DIN 863

Built-in **Bluetooth**

SIS Smart Inductive System

WATER RESISTANT

IP67

SWISS MADE

Knife-shaped 0.5mm - cone 60°/Ø0.5mm

* SIS description on page 5



Professional micrometer

S_Mike PRO

DIMENSIONAL DRAWING

KNIFE-SHAPED / CONE

Built-in Bluetooth **Cable crimping**

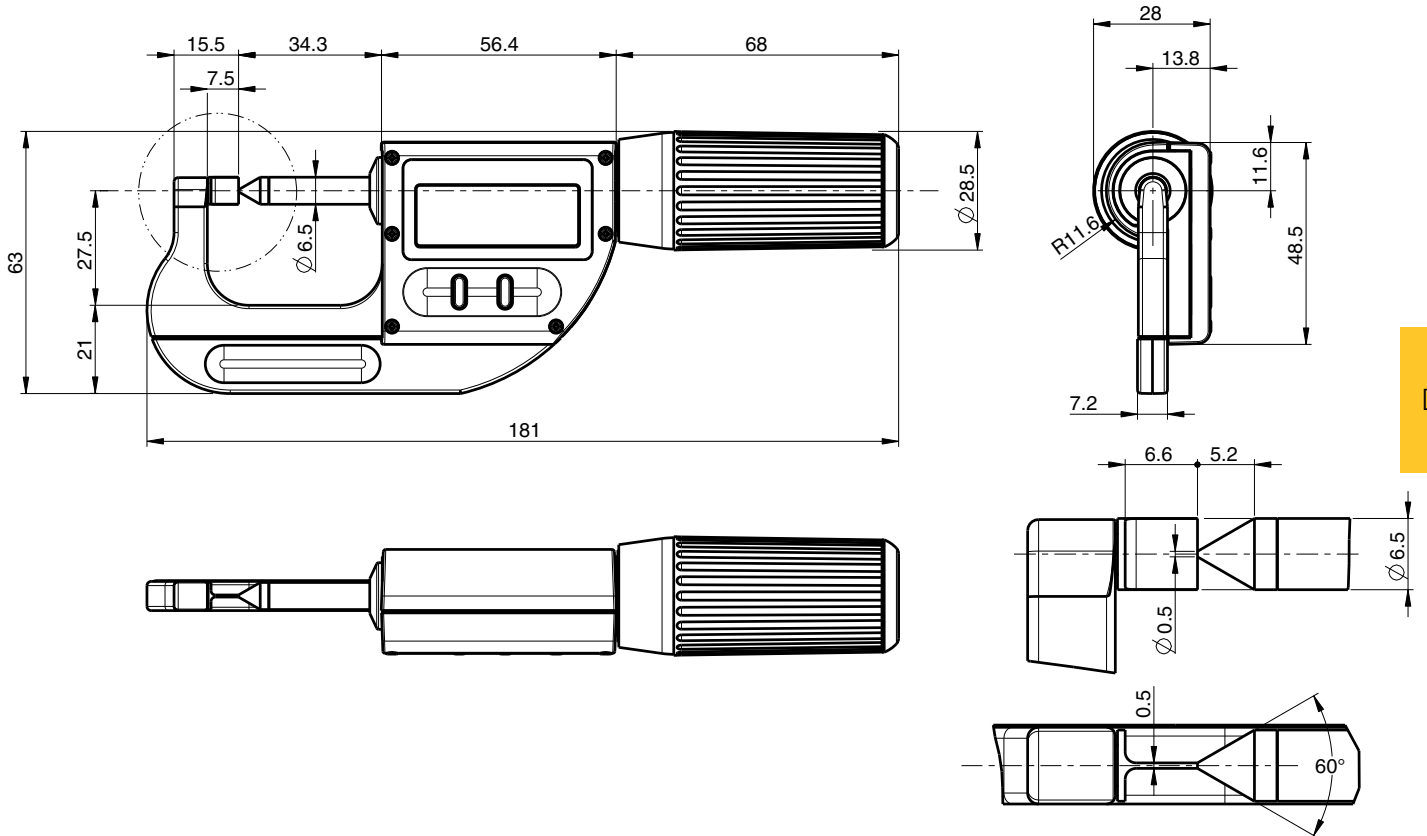

TECHNICAL SPECIFICATIONS

		803-0309
Measuring range	mm	0-25
Max. Error G ¹⁾	µm	3
Repeatability ²⁾	µm	1
Anvils types		Knife 0.5mm - cone 60°/∅0.5mm
Output data		Bluetooth® wireless technology*
Prot. rating accor. to IEC 60529		IP67 even connected
Setting by PC		●
Adjustable measuring force		5N / 10N
Non-rotating spindle		●
Fast movement		●
Preset function		●
Smart Inductive Sensor		●

¹⁾ according to DIN 863

²⁾ ± 1 digit

* Up to 8 instruments connected per dongle #981-7100

Professional micrometer

S_Mike PRO

DESCRIPTION

POINT / SPHERICAL

- High-speed micrometer with non-rotating spindle and integrated Bluetooth® system
- Linear spindle feed 10 mm per revolution
- Special instrument for checking splines
- 30° tapered hard metal measuring anvils with a small radius of 0.3 mm at the tip
- For technical reasons, this micrometer cannot be delivered with different anvils.
- Display resolution 0.001 mm
- Ratchet system cancels operator influence and guarantees excellent repeatability
- Switchable measuring force 5 or 10 N
- Measuring range limited to 25 mm
- Protection class IP67

D

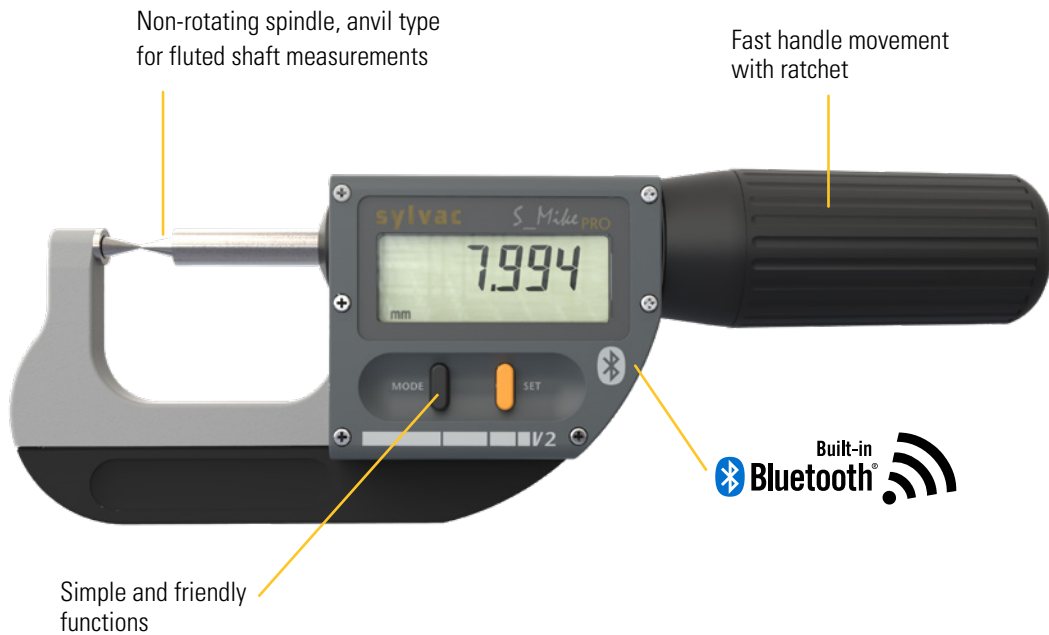

DIN 863



IP67



Point 30° - Spherical R0.3mm

* SIS description on page 5



Professional micrometer

S_Mike PRO

DIMENSIONAL DRAWING

POINT / SPHERICAL

Built-in Bluetooth® **Fluted Shaft**

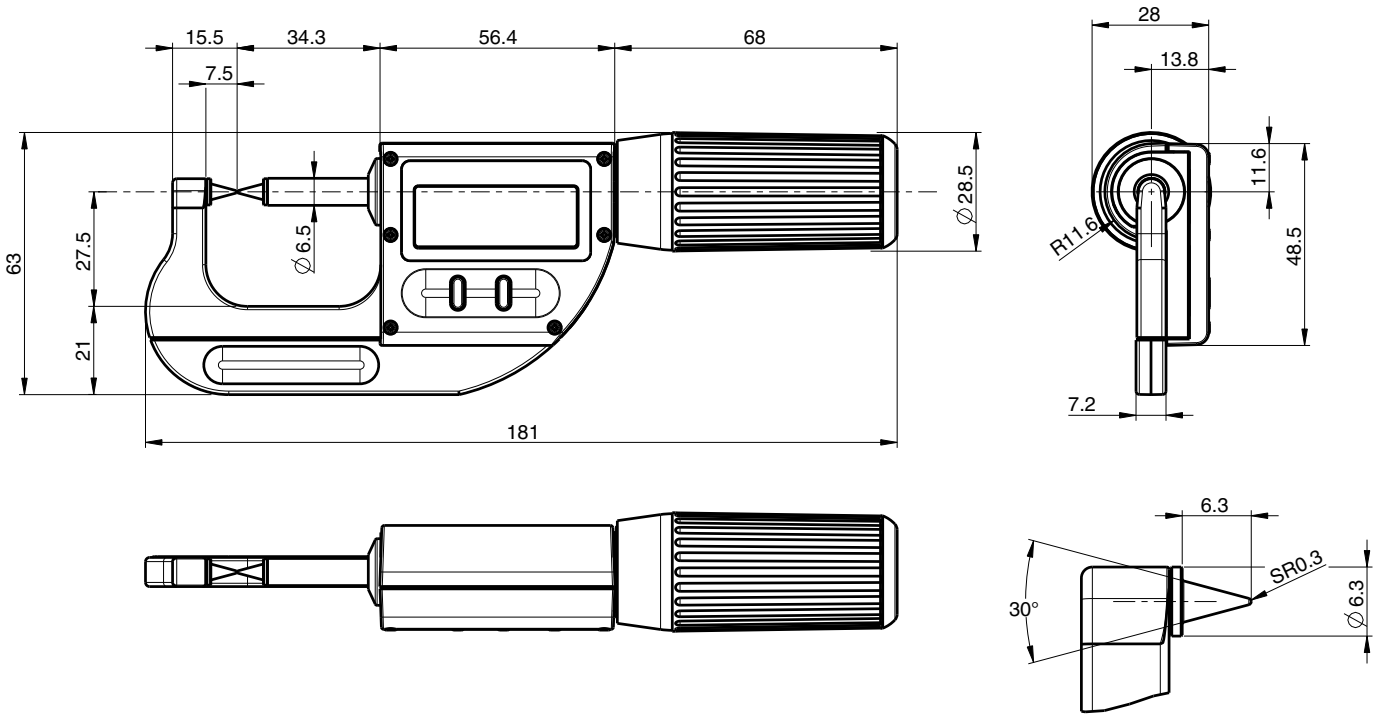

D

TECHNICAL SPECIFICATIONS

		803-0310
Measuring range	mm	0-25
Max. Error G ¹⁾	μm	3
Repeatability ²⁾	μm	1
Anvils types		Point 30° - spherical R0.3mm
Output data		Bluetooth® wireless technology*
Prot. rating accor. to IEC 60529		IP67 even connected
Setting by PC		●
Adjustable measuring force		5N / 10N
Non-rotating spindle		●
Fast movement		●
Preset function		●
Smart Inductive Sensor		●

¹⁾ according to DIN 863

²⁾ ± 1 digit

* Up to 8 instruments connected per dongle #981-7100

Professional micrometer

S_Mike PRO

STANDARD DELIVERY



903-1301



910-1301 including:
910-1502, 903-0300 and 903-0330



910-1304 including:
810-1506, 803-0306 and 805-6301

		903-1300	903-1301	910-1301	910-1304	903-1306
Measuring range	mm	0-102	0-102	150 / 0-30	150 / 0-30 / 12.5	0-102
Plastic case		●	-	-	●	●
Aluminium case		-	●	●	-	-
Output data		USB / RS 232			Bluetooth®	

STANDARD DELIVERY

- Instrument according to technical specifications
- Setting master 50 mm (for 903-060X)
- Setting master 75 mm (for 903-100X)
- Lithium battery CR2032 included
- Instruction manual
- Calibration certificate

MICROMETERS SETS

- 803-0300 / 903-0600 / 903-1000
- Setting master 50 mm
- Setting master 75 mm
- Lithium battery CR2032 included
- Instruction manual
- Calibration certificate

ACCESSORIES

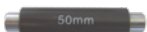
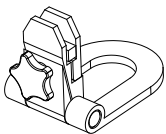

903-0330	Stand
903-0620	Setting master 50 mm
903-1020	Setting master 75 mm
903-1620	Setting master 125 mm



Professional micrometer

S_Mike PRO

MODELS



Cylindrical Ø6.5mm Proximity /
Cylindrical Ø6.5mm Smart



Disk Ø25mm



Ball-Ball Ø7mm



Flat Ø6.5mm-Ball Ø7mm



Knife 0.75x6.5mm



Cylindrical Ø2mm



Cable crimping Knife 0.5mm -
cone 30° / Ø0.5mm Smart



Fluted Shaft - Point 30° - ball
Ø0.3mm Smart

APPLICATIONS



Part measurement with a S_Mike PRO Disk



Length measurement of a lathed part



Cable crimping measurement



Professional micrometer

S_Mike EVO

DESCRIPTION

CYLINDRICAL Ø6.5

- New rotating spindle micrometer with integrated Bluetooth® system
- Spindle feed rate 1 mm per revolution
- Tungsten carbide measuring anvils Ø 6.5 mm
- Large XXL display with 0.001 mm resolution
- Measuring force 10N
- Measuring range up to 100mm
- Protection class IP67

D

Measuring surface in hard metal

Rotating spindle Ø 6.5 mm

Fast handle movement



Output Bluetooth® Wireless technology

Simple and friendly functions

* instrument soon available

DIN 863

Built-in
Bluetooth

SIS Smart Inductive System

WATER RESISTANT

IP67

Mounting unit (on request)



* SIS description on page 5



Professional micrometer

S_Mike EVO

DIMENSIONAL DRAWING

CYLINDRICAL Ø6.5

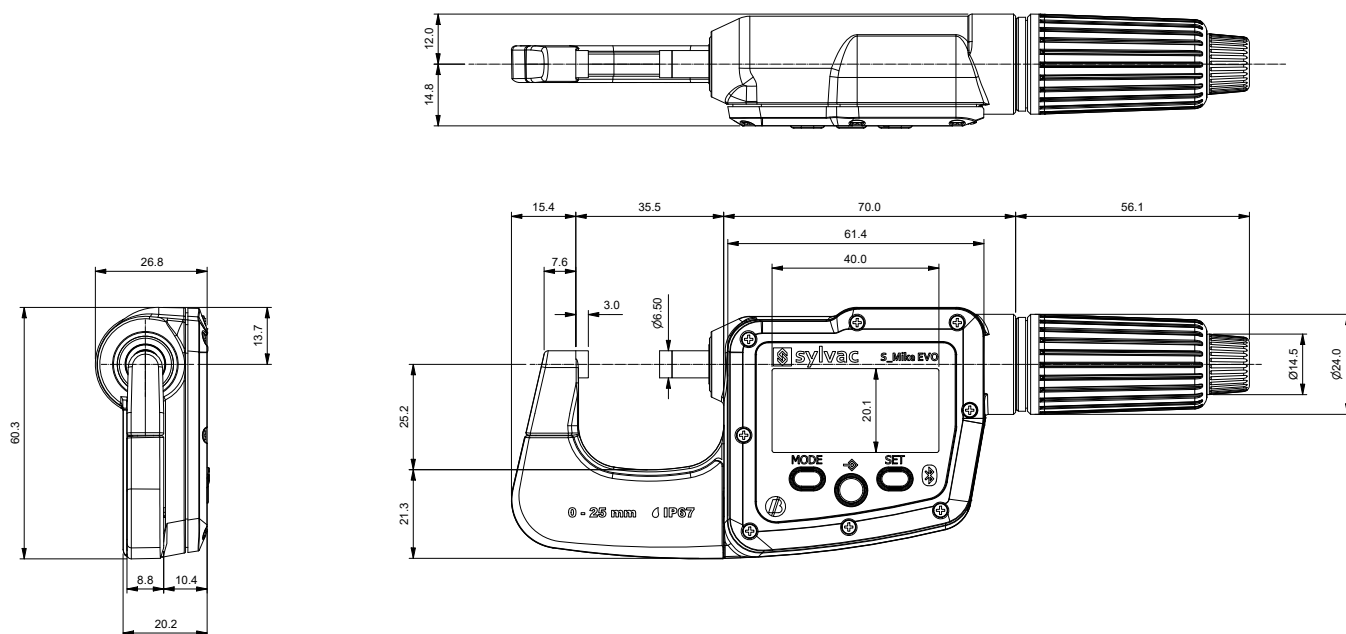

TECHNICAL SPECIFICATIONS

		803-6025	803-6050	803-6075	803-6100
Measuring range	mm	0-25	25-50	50-75	75-100
Max. Error G ¹⁾	µm	3	4	5	7
Repeatability ²⁾	µm	1	1	1	2
Anvils types		Ø6.5			
L	mm	35.5	61	86	112
B	mm	7.5	11	12	13
C	mm	25	37	50	63
D	mm	3	3	3	3
Output data		Bluetooth® wireless technology*			
Prot. rating accor. to IEC 60529		IP67 even connected			
Setting by PC		●			
Measuring force		10N			
Rotating spindle		●			
Advance		1mm/rotation			
Preset function		●			
Smart Inductive Sensor		●			

¹⁾ according to DIN 863

²⁾ ± 1 digit

³⁾ see cables chapter

* Up to 8 instruments connected per dongle #981-7100