



A

DIGITAL INDICATORS S_DIAL

Digital comparators have contributed greatly to Sylvac's success and reputation for decades. Sylvac can therefore be considered the world leader in this type of instrument, thanks to the wide range of products available, but also because of the specifications and advanced functions offered by the dial indicators that you will find in this chapter.

GENERAL CHARACTERISTICS :

- **Powered by lithium battery type CR2032**
- **Absolute measuring system S.I.S**
- **Automatic sleep and wake-up**
- **mm/inch conversion on all models**
- **Working temperature +5° to +40°C**
- **Comparators supplied with interchangeable steel M2.5 contact point, with tungsten carbide ball Ø 2 mm**





Digital indicators

S_Dial

SUMMARY OF ALL TYPES

B

	S_Dial MINI								S_Dial TEST					S_Dial WORK																		
	BASIC				SMART									BASIC		ANALOG		CBG		ADVANCED IP67		PLC										
RANGE	805-4121	805-4125	805-4521	805-4525	805-6121	805-6123	805-6125	805-6521	805-6523	805-6525	805-4321	805-4322	805-4323	805-1201	805-1301	805-1401	805-1501	805-1601	805-1621	805-5307	805-5507	805-6308	805-6317	805-5305	805-5505	805-5625	805-7301	805-7201	805-7501	805-7401		
0.8 mm											•		•																			
2.0 mm												•			•																	
12.5 mm	•	•	•	•	•	•	•	•	•	•				•	•					•		•	•	•			•	•				
25 mm																•	•				•				•				•	•		
50 mm																		•	•							•						
100 mm																																
150 mm																																
RESOLUTION																																
0.01 mm	•	•			•	•	•							•		•	•	•											•	•		
0.001 mm			•	•				•	•	•	•	•			•		•	•	•		•	•	•	•	•	•	•	•	•	•		
MECHANIC																																
Diameter 8 mm h6	•	•	•	•	•	•	•	•	•	•				•	•	•	•	•		•	•	•	•	•	•	•	•	•	•	•		
Diameter 25mm g7																																
Dove tail	•	•	•	•	•	•	•	•	•	•	•	•																				
M1.4 contact point											•	•	•																			
M2.5 contact point	•	•	•	•	•	•	•	•	•	•				•	•	•	•	•	•		•	•	•	•	•	•	•	•	•	•		
Rubber boot	•		•			•			•																•	•	•					
IP51 (IEC 60529)														•	•	•	•	•	•													
IP54 (IEC 60529)	•		•								•	•	•							•	•	•	•	•	•	•	•	•	•	•		
IP65 (IEC 60529)																																
IP67 (IEC 60529)	•		•	•	•	•	•	•	•	•															•	•	•	•	•	•		
DIAL																																
Diameter 45 mm	•	•	•	•	•	•	•	•	•	•	•	•																				
Diameter 60 mm														•	•	•	•	•	•		•	•	•	•	•	•	•	•	•	•		
Rotating											•	•	•								•	•	•	•	•	•	•	•	•	•		
Lifting cap	•	•	•	•	•		•							•	•	•	•	•	•		•	•	•	•	•	•	•	•	•	•		
FUNCTIONS																																
mm/inch	•	•	•	•	•	•	•	•	•	•	•	•	•	•	•	•	•	•	•		•	•	•	•	•	•	•	•	•	•		
Preset	•1)	•1)	•1)	•1)	•	•	•	•	•	•	•	•	•	•1)	•1)	•1)	•1)	•1)	•1)		•	•	•	•	•	•	•	•	•	•		
Preset dynamic																					•	•	•	•	•	•	•	•	•	•		
Measuring direction	•	•	•	•	•	•	•	•	•	•	•	•	•	•	•	•	•	•	•		•	•	•	•	•	•	•	•	•	•		
Hold					•	•	•	•	•	•	•	•	•								•	•	•	•	•	•	•	•	•	•		
Min / Max / Delta					•	•	•	•	•	•	•	•	•								•	•	•	•	•	•	•	•	•	•		
Tolerances																					•	•	•	•	•	•	•	•	•	•		
Absolute system S.I.S.*	•	•	•	•	•	•	•	•	•	•	•	•	•	•	•	•	•	•	•		•	•	•	•	•	•	•	•	•	•		
Auto off	•	•	•	•	•	•	•	•	•	•	•	•	•	•	•	•	•	•	•		•	•	•	•	•	•	•	•	•	•		
Analog display					•	•	•	•	•	•	•	•	•								•	•	•	•	•	•	•	•	•	•		
Setting by PC	•	•	•	•	•	•	•	•	•	•	•	•	•	•	•	•	•	•	•		•	•	•	•	•	•	•	•	•	•		
Programmable menus					•	•	•	•	•	•	•	•	•	•	•	•	•	•	•		•	•	•	•	•	•	•	•	•	•		
Powered by connector	•	•	•	•	•	•	•	•	•	•	•	•	•	•	•	•	•	•	•		•	•	•	•	•	•	•	•	•	•		
Multiplication factor					•	•	•	•	•	•	•	•	•								•	•	•	•	•	•	•	•	•	•		
Ref I / II																							2)	2)	•	•	•	•	•	•		

* SIS description on page 5

Models with Bluetooth® technology

1) Preset configuration only by PC
2) 4 references



Digital indicators

S_Dial

SUMMARY OF ALL TYPES

	S_Dial WORK																ANALOG NANO SMART		S_Dial PRO									
	ADVANCED								SMART				NANO & NANO SMART				SMART											
	805-5201	805-5301	805-5401	805-5501	805-5601	805-5621	805-5641	805-5661	805-5671	805-5681	805-6301	805-6501	805-6621	805-6661	805-5306	805-5506	805-6306	805-6506	805-6307	805-6507	805-8601	805-8701	805-8602	805-8702	805-8501	805-8502	805-8661	
RANGE																												
0.8 mm																												
2.0 mm																												
12.5 mm	•	•									•				•		•		•									
25 mm			•	•								•				•		•		•						•	•	
50 mm					•	•							•								•	•		•	•			
100 mm							•	•						•										•	•			•
150 mm									•	•																		
RESOLUTION																												
0.01 mm	•		•		•		•		•																			
0.001 mm		•		•		•		•		•	•		•															
0.0001 mm															•	•	•	•	•	•	•	•	•	•	•	•	•	•
MECHANIC																												
Diameter 8 mm h6	•	•	•	•	•	•	•	•	•	•	•	•	•	•	•	•	•	•	•	•	•	•	•	•	•	•	•	•
Diameter 25 mm g7																							•	•				
Spring	•	•	•	•	•	•	•	•	•	•	•	•	•	•	•	•	•	•	•	•	•	•	•	•	•	•	•	•
M1.4 contact point																												
M2.5 contact point	•	•	•	•	•	•	•	•	•	•	•	•	•	•	•	•	•	•	•	•	•	•	•	•	•	•	•	•
Rubber boot																												
IP51 (IEC 60529)																						•	•	•	•	•	•	•
IP54 (IEC 60529)	•	•	•	•	•	•	•	•	•	•	•	•	•	•	•	•	•	•	•	•	•							
DIAL																												
Diameter 60 mm	•	•	•	•	•	•	•	•	•	•	•	•	•	•	•	•	•	•	•	•	•	•	•	•	•	•	•	•
Rotating	•	•	•	•	•	•	•	•	•	•	•	•	•	•	•	•	•	•	•	•	•	•	•	•	•	•	•	•
FUNCTIONS																												
mm/inch	•	•	•	•	•	•	•	•	•	•	•	•	•	•	•	•	•	•	•	•	•	•	•	•	•	•	•	•
Preset	•	•	•	•	•	•	•	•	•	•	•	•	•	•	•	•	•	•	•	•	•	•	•	•	•	•	•	•
Preset dynamic																					•	•						
Measuring direction	•	•	•	•	•	•	•	•	•	•	•	•	•	•	•	•	•	•	•	•	•	•	•	•	•	•	•	•
Hold	•	•	•	•	•	•	•	•	•	•	•	•	•	•	•	•	•	•	•	•	•	•	•	•	•	•	•	•
Min / Max / Delta	•	•	•	•	•	•	•	•	•	•	•	•	•	•	•	•	•	•	•	•	•	•	•	•	•	•	•	•
Tolerances	•	•	•	•	•	•	•	•	•	•	•	•	•	•	•	•	•	•	•	•	•	•	•	•	•	•	•	•
Absolute system S.I.S*	•	•	•	•	•	•	•	•	•	•	•	•	•	•	•	•	•	•	•	•	•	•	•	•	•	•	•	•
Auto off	•	•	•	•	•	•	•	•	•	•	•	•	•	•	•	•	•	•	•	•	•	•	•	•	•	•	•	•
Analog display																					•	•						
Setting by PC	•	•	•	•	•	•	•	•	•	•	•	•	•	•	•	•	•	•	•	•	•	•	•	•	•	•	•	•
Programmable menus	•	•	•	•	•	•	•	•	•	•	•	•	•	•	•	•	•	•	•	•	•	•	•	•	•	•	•	•
Powered by connector	•	•	•	•	•	•	•	•	•	•	•	•	•	•	•	•	•	•	•	•	•	•	•	•	•	•	•	•
Multiplication factor	•	•	•	•	•	•	•	•	•	•	•	•	•	•	•	•	•	•	•	•	•	•	•	•	•	•	•	•
Ref I / II	•	•	•	•	•	•	•	•	•	•	•	•	•	•	•	•	•	•	•	•	•	•	•	•	•	•	•	•

B



Digital test indicator

S_Dial TEST Smart

DESCRIPTION

- First digital test indicator with integrated Bluetooth® system
- Instrument for checking roundness and flatness
- Data transfer by sending a request or by foot pedal
- Compact housing Ø 45 mm rotatable by 270°.
- Revolutionary mechanical construction, without gears or gears, which eliminates hysteresis error
- Digital display resolution 0.001 mm with analogue scale
- M1.4 stylus with Ø 2 mm tungsten carbide ball, swivelling and interchangeable
- Available in 3 versions :
 - Model with stylus length 12 mm, measuring range 0.8 mm
 - Model with stylus length 36 mm, measuring range 2.0 mm
 - Combination model for 12 and 36 mm styli (supplied with both styli), measuring range 0.8/2.0 mm
- Protected against liquids IP54



B

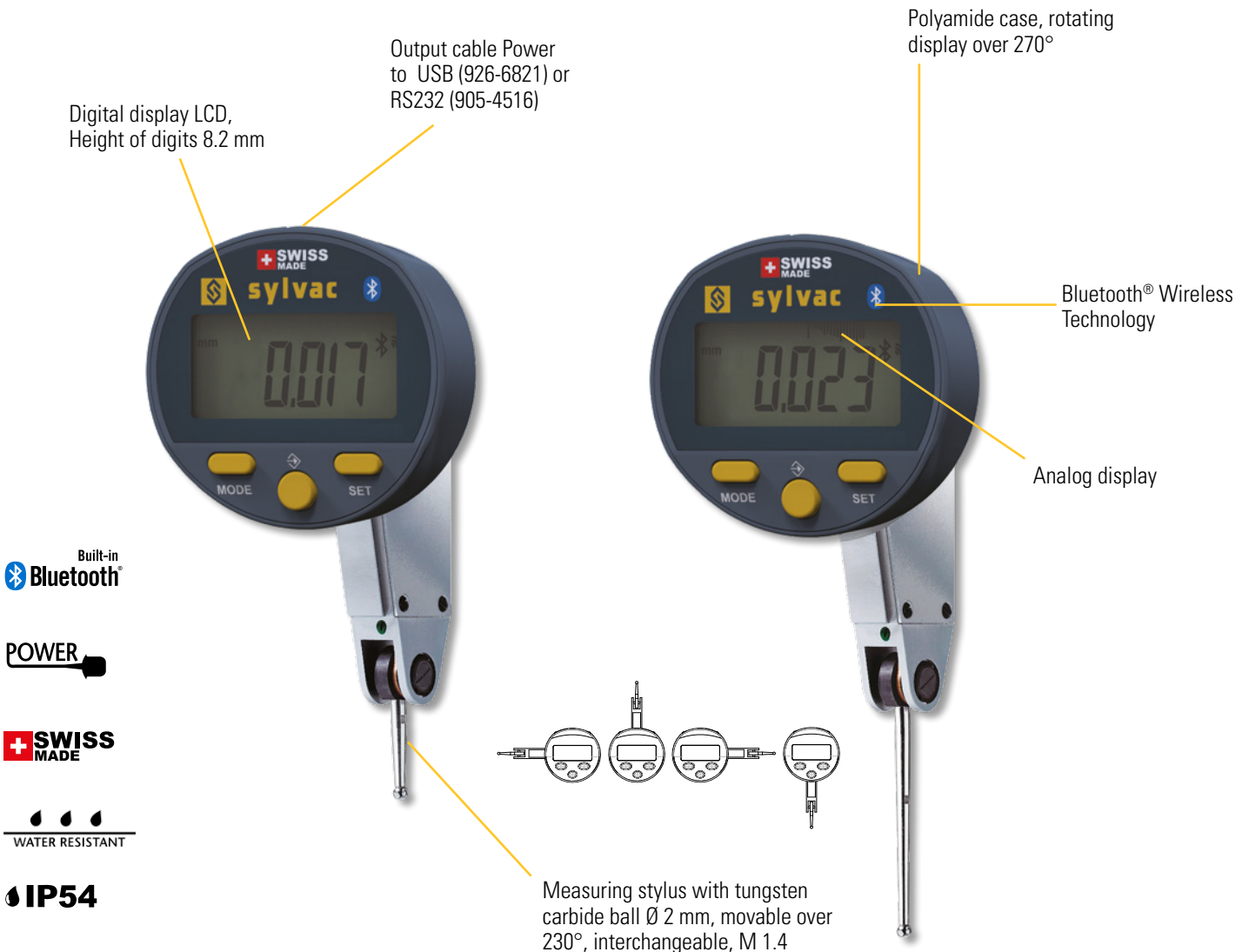



Digital test indicator

S_Dial TEST Smart

DIMENSIONAL DRAWING

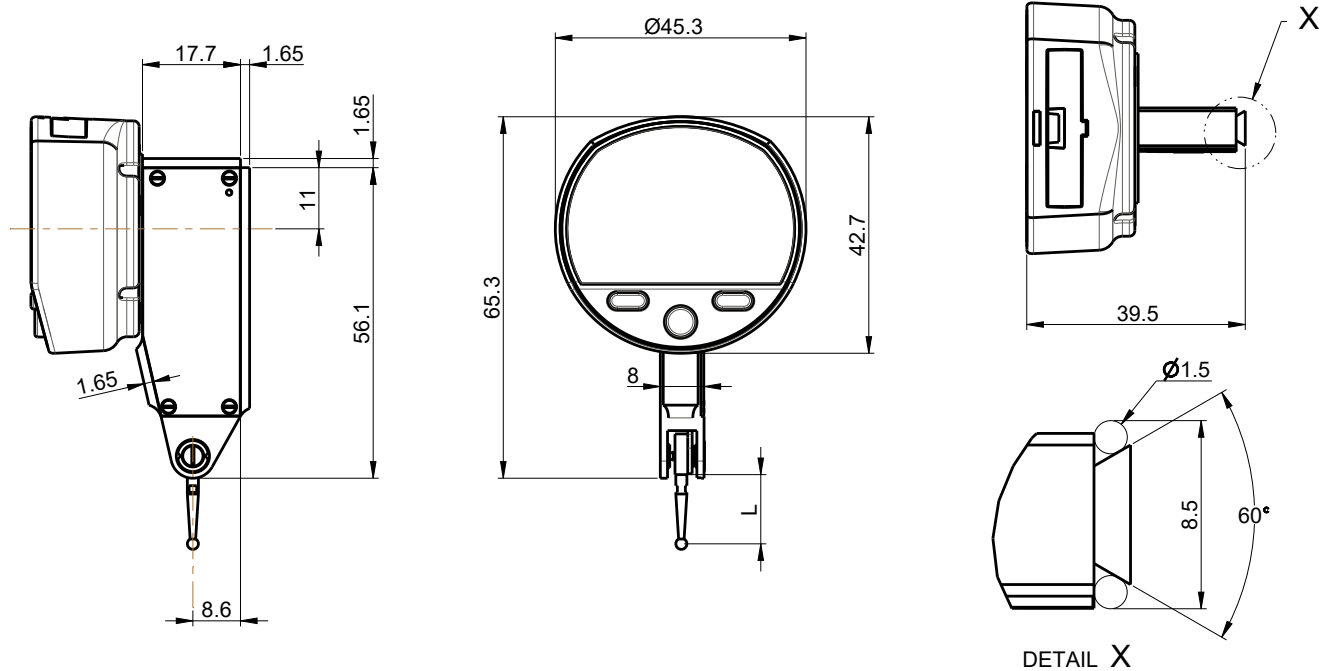

TECHNICAL SPECIFICATIONS

		805-4321	805-4322	805-4323
Measurement capacity	mm	0.8	2.0	0.8 / 2.0
Stylus length L	mm	12.5	36.5	12.5 / 36.5
Accuracy f_e ($\alpha=0^\circ$)	μm	3	8	3 / 8
Total accuracy f_{ges} ($\alpha=0^\circ$)	μm	4	10	4 / 10
Reversibility f_u	μm	2	3	2 / 3
Resolution	mm	0.001mm / .00005"		
Repeatability f_w	μm	1		
Measuring force	N	0.15	0.06	0.15 / 0.06
Friction on probe orientation	N	4	1.6	4 / 1.6
Weight	g	70		
Protection rating according to IEC 60529		IP54		
Output data		Bluetooth® wireless technology* / RS232 / USB ¹⁾		
Zero setting		●		
min / max / delta display		●		
Analog display		●		
Selection of resolution		●		
Preset (0.01 resolution)		$\pm 99.999 \text{ mm} / \pm 3.99995 \text{ IN} (\pm 999.99 \text{ mm} / \pm 39.9995 \text{ IN})$		

¹⁾ see cables chapter

* Up to 8 instruments connected per dongle #981-7100

B

Digital test indicator

S_Dial TEST Smart

DISPLAY

- ❶ Direct mm/inch conversion
- ❷ Analog display
- ❸ Min/max/delta mode
- ❹ Analogic resolution display
- ❺ Bluetooth® technology

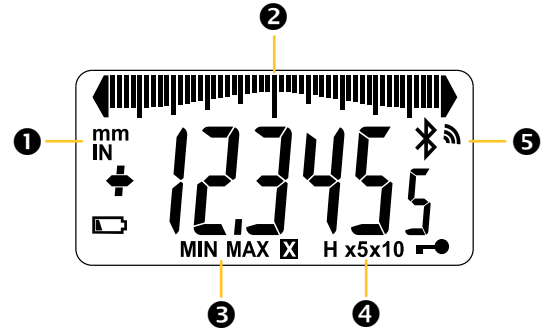

STANDARD DELIVERY

- Instrument according to technical specifications
- Lithium battery CR2032 included
- Quickstart
- Stem Ø 8 mm (905-2247)
- Clamping key for measuring button
- 2 contact points Ø2mm, 12.5 and 36.5mm (model 805-4332 only)

APPLICATIONS



Run-out measurement



Checking the alignment on milling machine.

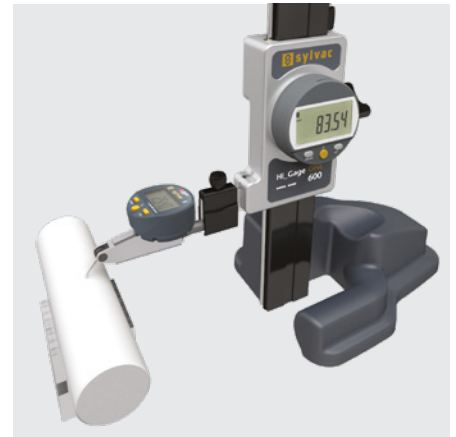

Perpendicularity measurement with a S234 mounted on a Hi_Gage ONE



Mini digital indicators

S_Dial MINI Basic

DESCRIPTION

- Smallest digital comparator available on the market, with compact Ø 45 mm non-rotating housing
- New robust construction
- Ideal for integration into machines or various measuring fixtures
- Only one central button with favourite function to choose between recall of the preset or transmission of the value
- Selection of unit (mm/inch) and direction of measurement
- Data output «Power», works without battery when connected via cable
- Digital display resolution 0.01 or 0.001 mm
- Measuring range 12.5 mm
- Available in Protected or Standard execution
 - P version: IP67 with bellows-protected spindle, without lifting cap
 - S version: IP54, without bellows, with lifting cap

B

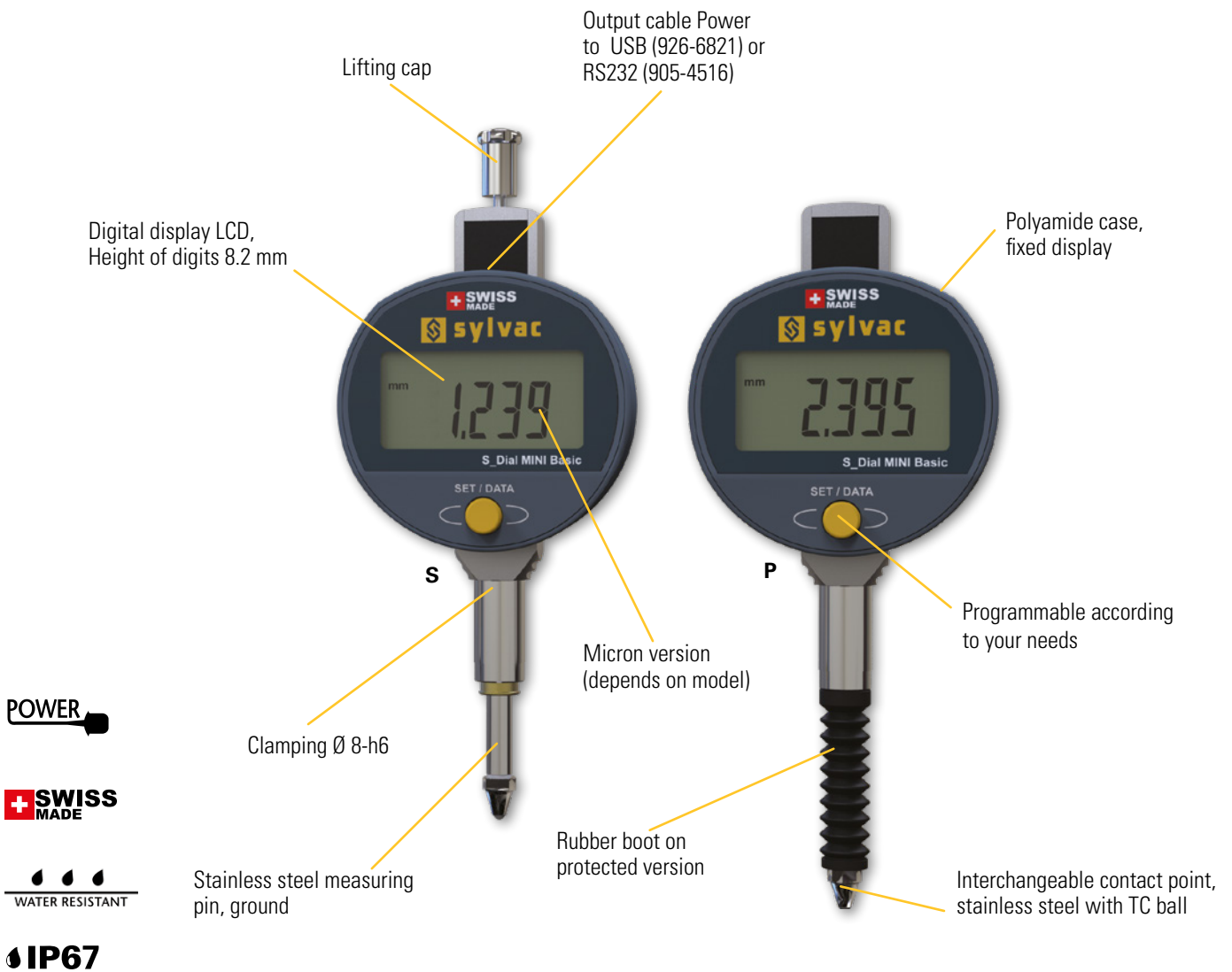

Mini digital indicators

S_Dial MINI Basic

DIMENSIONAL DRAWINGS

B

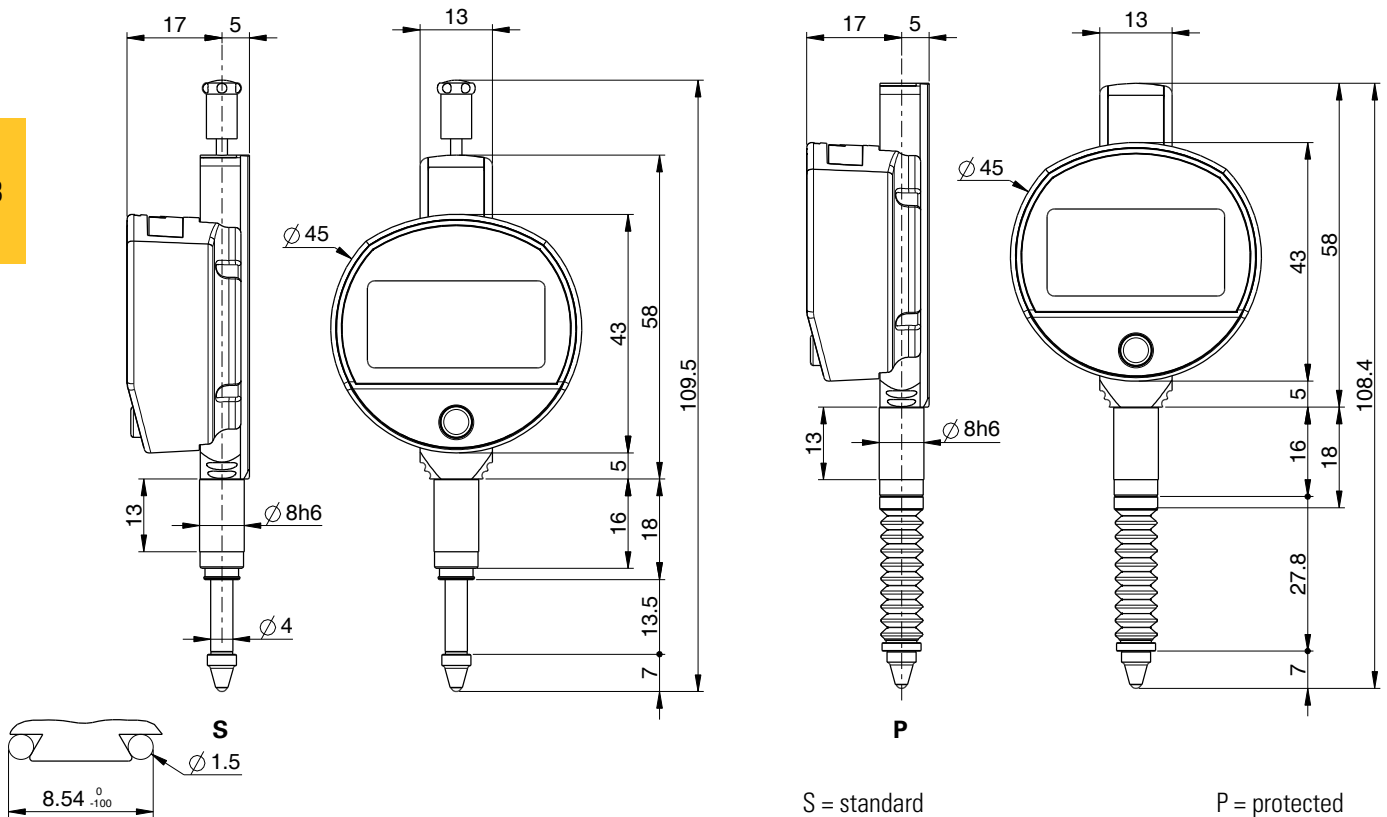

S = standard

P = protected

TECHNICAL SPECIFICATIONS

		805-4121	805-4125	805-4521	805-4525
Measuring range	mm	12.5	12.5	12.5	12.5
Analog scale		---	---	---	---
Resolution	mm	0.01	0.01	0.001	0.001
Execution ³⁾		S	P	S	P
Max. Error fe	µm	10 ¹⁾	10 ¹⁾	4	4
Repeatability	µm	2	2	2	2
Measuring force ²⁾	N	0.5 - 0.90 N	0.6 - 1.3 N	0.5 - 0.90 N	0.6 - 1.3 N
Zero setting				●	
Resolution selection				---	
PRESET = (max. ±999.99 mm)				● ⁵⁾	
Min / max / delta display				---	
Selection of measuring direction				●	
Multiplication factor				---	
Output data				USB / RS232 ⁴⁾	
IP rating		IP54	IP67	IP54	IP67

¹⁾ ± 1 digit

²⁾ Values ± 20%, indicator in vertical position, outgoing measuring spindle

³⁾ S = Standard P = Protected

⁴⁾ see cables chapter

⁴⁾ voir chapitre câbles

⁵⁾ Preset configuration only by computer



Mini digital indicators

S_Dial MINI Smart

DESCRIPTION

- Smallest digital comparator available on the market with compact Ø 45 mm non-rotating housing and integrated Bluetooth® system
- New robust construction
- Ideal for integration into machines or various measuring fixtures
- Data output «Power», works without battery when connected via cable
- Three buttons, including the central button with selectable favourite function
- Wide range of functions, including MIN/MAX/DELTA
- Digital display resolution 0.01 or 0.001 mm with analogue scale
- Measuring range 12.5 mm
- Available in Protected or Standard execution
 - P version: IP67 with bellows-protected spindle, without lifting cap
 - S version: IP54 or IP67, without bellows, with or without lifting cap

B



Mini digital indicators

S_Dial MINI Smart

B

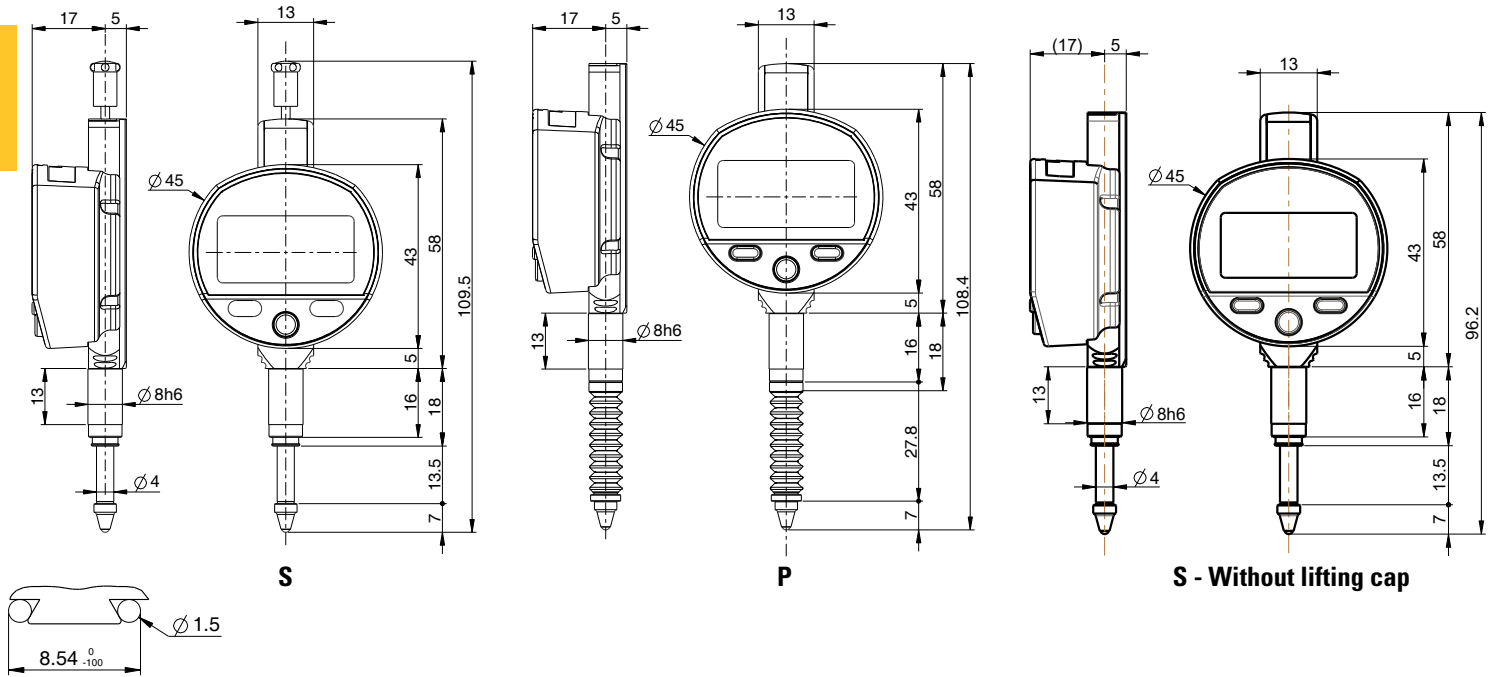

Smart		805-6121	805-6123	805-6125	805-6521	805-6523	805-6525
Measuring range	mm	12.5	12.5	12.5	12.5	12.5	12.5
Analog scale		●	●	●	●	●	●
Resolution	mm	0.01	0.01	0.01	0.001	0.001	0.001
Execution ³⁾		S	S	P	S	S	P
Max. Error fe	µm	10 ¹⁾	10 ¹⁾	10 ¹⁾	4	4	4
Repeatability	µm	2	2	2	2	2	2
Measuring force ²⁾	N	0.5 - 0.90 N	0.5 - 0.90 N	0.6 - 1.3 N	0.5 - 0.90 N	0.5 - 0.90 N	0.6 - 1.3 N
Lifting cap		●			●		
Zero setting					●		
Resolution selection					●		
PRESET = (max. ±999.99 mm)					●		
Min / max / delta display					●		
Selection of measuring direction					●		
Multiplication factor					●		
Output data		Bluetooth® wireless technology* / RS232 / USB ⁴⁾					
IP rating		IP67	IP67	IP67	IP67	IP67	IP67

¹⁾ ± 1 digit

²⁾ Values ± 20%, indicator in vertical position, outgoing measuring spindle

³⁾ S = Standard P = Protected

⁴⁾ see cables chapter

* Up to 8 instruments connected per dongle #981-7100



Mini digital indicators

S_Dial MINI Smart

STANDARD DELIVERY

- Instrument according to technical specifications
- Lithium battery CR2032 included
- Instruction manual
- Calibration certificate for instruments with resolution 0.001 mm

B

MEASURING FORCE FOR RANGE 12.5 mm

	S	P
Standard	0.5 - 0.90 N	0.6 - 1.3 N
Low ¹⁾	0.35 - 0.50 N	---
High ¹⁾	1.80 - 2.3 N	---

Tolerance $\pm 20\%$, indicator in vertical position, spindle in outgoing measurement.
¹⁾ on request

APPLICATIONS



Checking of an internal \varnothing with a mechanical device



Measurement of the vertical displacement of an element



Measurement of internal chamfer

Digital indicators

S_Dial WORK

DESCRIPTION

BASIC

- Simple and robust digital comparator with \varnothing 59.5 mm non-rotating housing
- One central button with favourite function to choose between preset recall or value transmission
- Selection of unit (mm/inch) and direction of measurement
- Proximity» and «Power» data outputs allowing the instrument to be used without batteries when connected by this cable.
- Available in version with display resolution 0.01 mm and 0.001 mm
- Measuring range selectable: 12.5, 25 and 50 mm

B

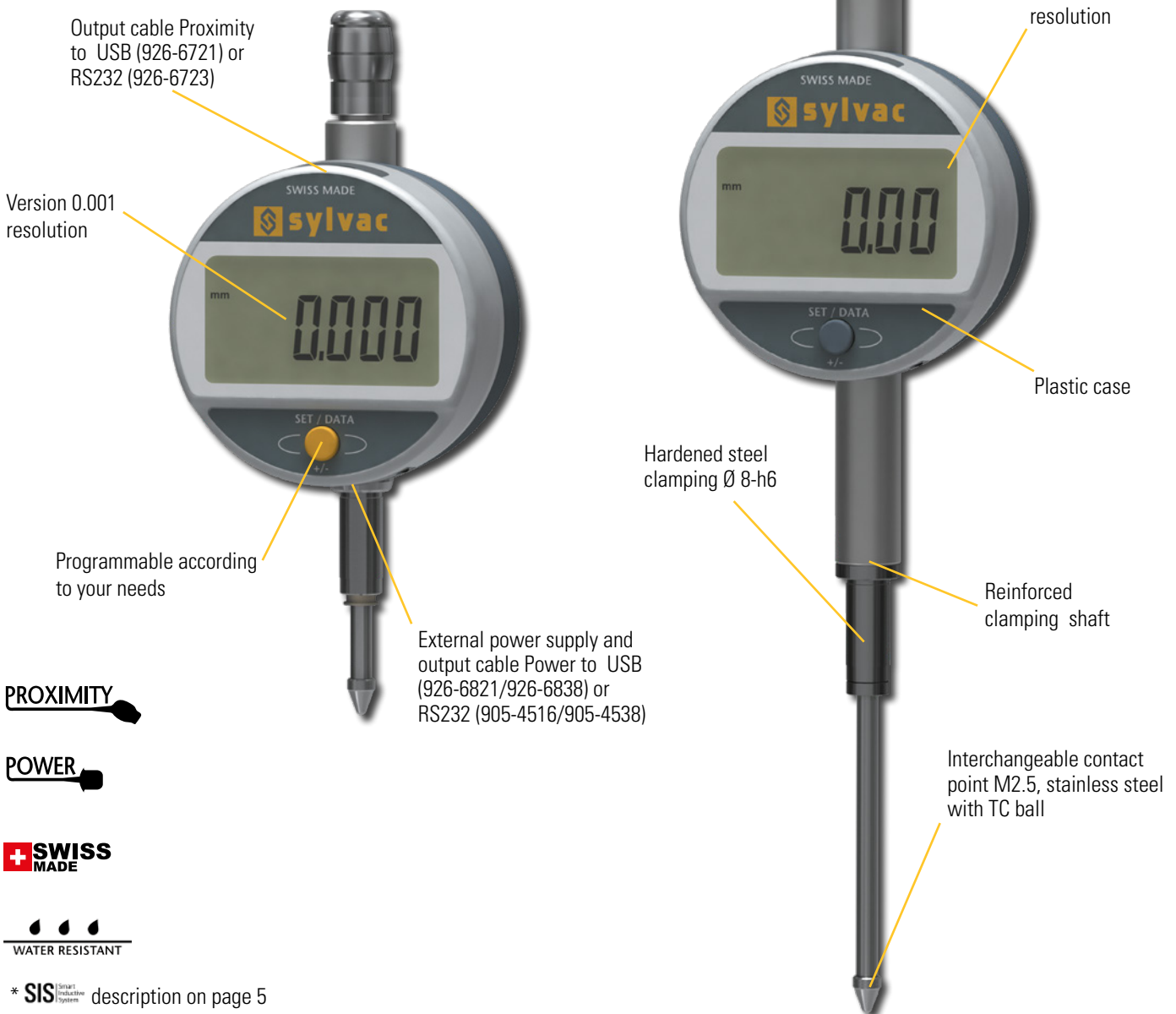



Digital indicators

S_Dial WORK

DIMENSIONAL DRAWINGS

BASIC

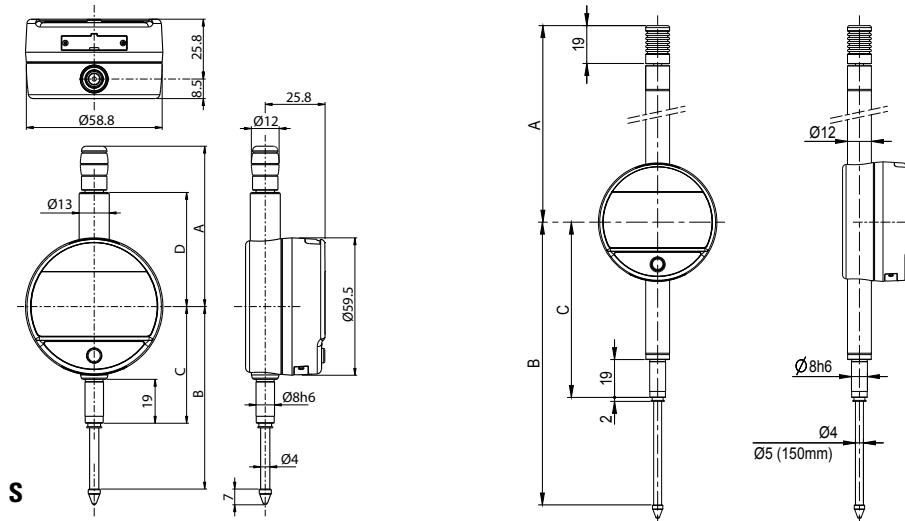

TECHNICAL SPECIFICATIONS

		805-1201	805-1301	805-1401	805.1501	805-1601	805-1621
Measuring range	mm	12.5	12.5	25	25	50	50
Resolution	mm	0.01	0.001	0.01	0.001	0.01	0.001
Max. Error fe	µm	10 ¹⁾	4	10 ¹⁾	5	20 ¹⁾	7
Repeatability	µm	2					
IP rating		IP51					
A	mm	56.7		69.9		121.3	
B	mm	66.1		78.5		142	
C	mm	50.5		50.5		88	
D	mm	36.6		49.4		-	
Output data		USB / RS232					
Programmable by PC		●					
Standard functions (customized by PC)		Preset (max 999.999) only programmable by PC with cable, mm/inch, direction of measurement					

¹⁾ ± 1 digit

STANDARD DELIVERY

MEASURING FORCE

- Instrument according to technical specifications
- Lithium battery CR2032 included
- Instruction manual
- Calibration certificate for instruments 0.001 mm

		S 12.5	S 25	S 50
Standard	N	0.65 - 0.90	0.65 - 1.15	1.1 - 2.6
Low ³⁾	N	0.4 - 0.55	0.45 - 0.9	---
High ³⁾	N	1.0 - 1.6	0.9 - 1.8	---

Tolerance ± 20%, spindle in outgoing measurement position.
³⁾ on request



Digital indicators

S_Dial WORK

DESCRIPTION

ADVANCED

- Robust digital comparator with Ø 59.5 mm housing rotatable by 270°.
- Large display with colour LED tolerance status indication
- Three buttons, including the central button with selectable favourite function
- Wide range of functions, including MIN/MAX/DELTA
- Proximity» and «Power» data outputs allowing the instrument to be used without batteries when connected by this cable.
- Available with display resolution 0.01 mm or 0.001 mm
- Measuring range selectable: 12.5, 25, 50, 100 and 150 mm
- The 12.5 and 25 mm versions are available in special low or high pressure versions on request.
- Protected IP54

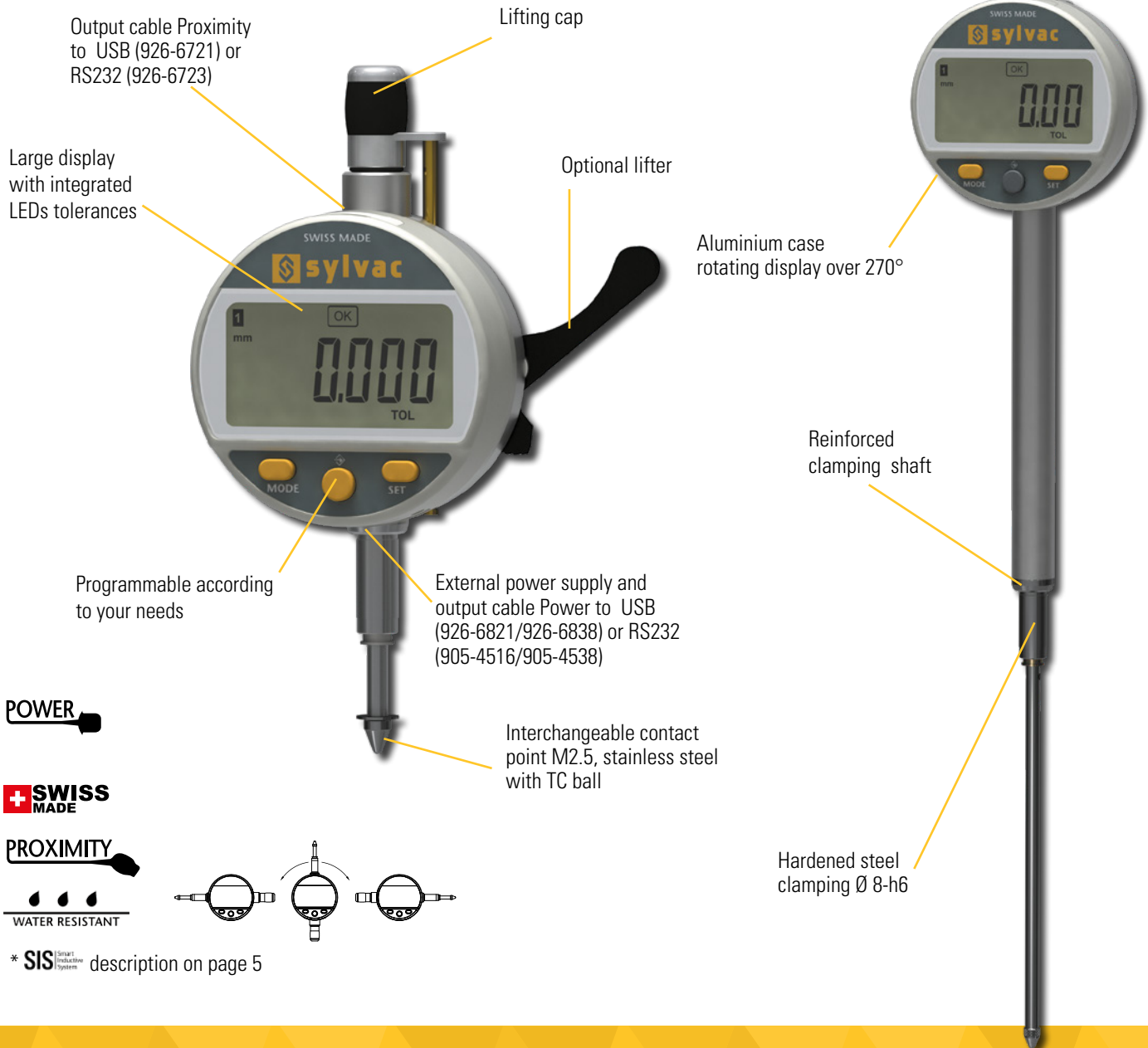

POWER

SWISS MADE

PROXIMITY

 WATER RESISTANT

* SIS description on page 5



Digital indicators

S_Dial WORK

DIMENSIONAL DRAWINGS

ADVANCED

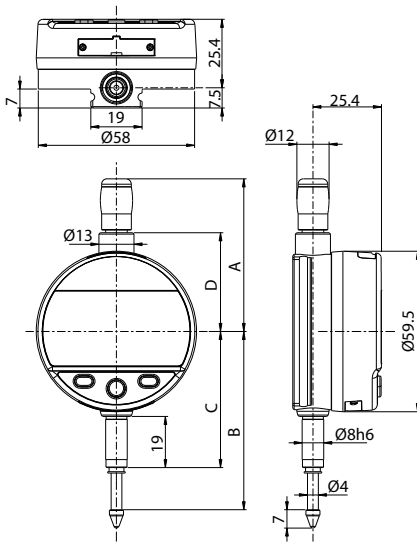

S 12.5-25 mm

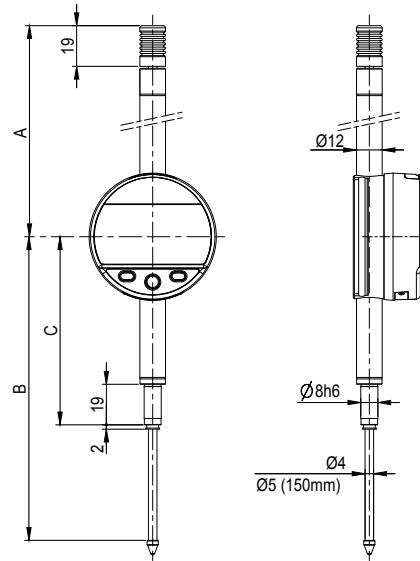

S 50-150 mm



TECHNICAL SPECIFICATIONS

		805-5201	805-5301	805-5401	805-5501	805-5601	805-5621	805-5641	805-5661	805-5671	805-5681
Measuring range	mm	12.5	12.5	25	25	50	50	100	100	150	150
Resolution	mm	0.01	0.001	0.01	0.001	0.01	0.001	0.01	0.001	0.01	0.001
Max. Error fe	µm	10 ¹⁾	3	10 ¹⁾	4	20 ¹⁾	5	20 ¹⁾	6	20 ¹⁾	10
Repeatability	µm	2									
IP rating		IP54									
A	mm	56.7		69.4		121		172		224	
B	mm	66.1		78.5		142		244		349	
C	mm	50.5		50.5		88		139		193	
D	mm	36.6		49.4		-		-		-	
Output data		USB / RS232									
Programmable by PC		●									
Standard functions (customized by PC)		mm/inch, ref I/II, preset (max 999.999) min/max/delta, tolerances, resolution, direction of measurement, multiplication factor, automatic or manual switch off, key lock									

¹⁾ ± 1 digit

STANDARD DELIVERY

MEASURING FORCE

- Instrument according to technical specifications
- Lithium battery CR2032 included
- Instruction manual
- Calibration certificate for instruments 0.001 mm

		12.5	25	50	100	150
Standard	N	0.65 - 0.9	0.65 - 1.15	1.1 - 2.6	1.8 - 3.8	2.6 - 5.7
Low ²⁾	N	0.4 - 0.55	0.45 - 0.9	---	---	---
High ²⁾	N	1.0 - 1.6	0.9 - 1.8	---	---	---

Tolerance ± 20%, spindle in outgoing measurement position.
²⁾ on request



Digital indicators

S_Dial WORK

DESCRIPTION

ADVANCED IP67

- Robust digital comparator with Ø 59.5 mm housing rotatable by 270°.
- Large display with 0.001 mm resolution and colour LED tolerance status indication
- Three buttons, including the central button with selectable favourite function
- Wide range of functions, including MIN/MAX/DELTA
- Proximity» and «Power» data outputs allowing the instrument to be used without batteries when connected by this cable.
- Measuring range selectable: 12.5, 25 and 50 mm
- IP67 protection with bellows-protected stem and dust cap
- Brake valve on 50 mm version

B

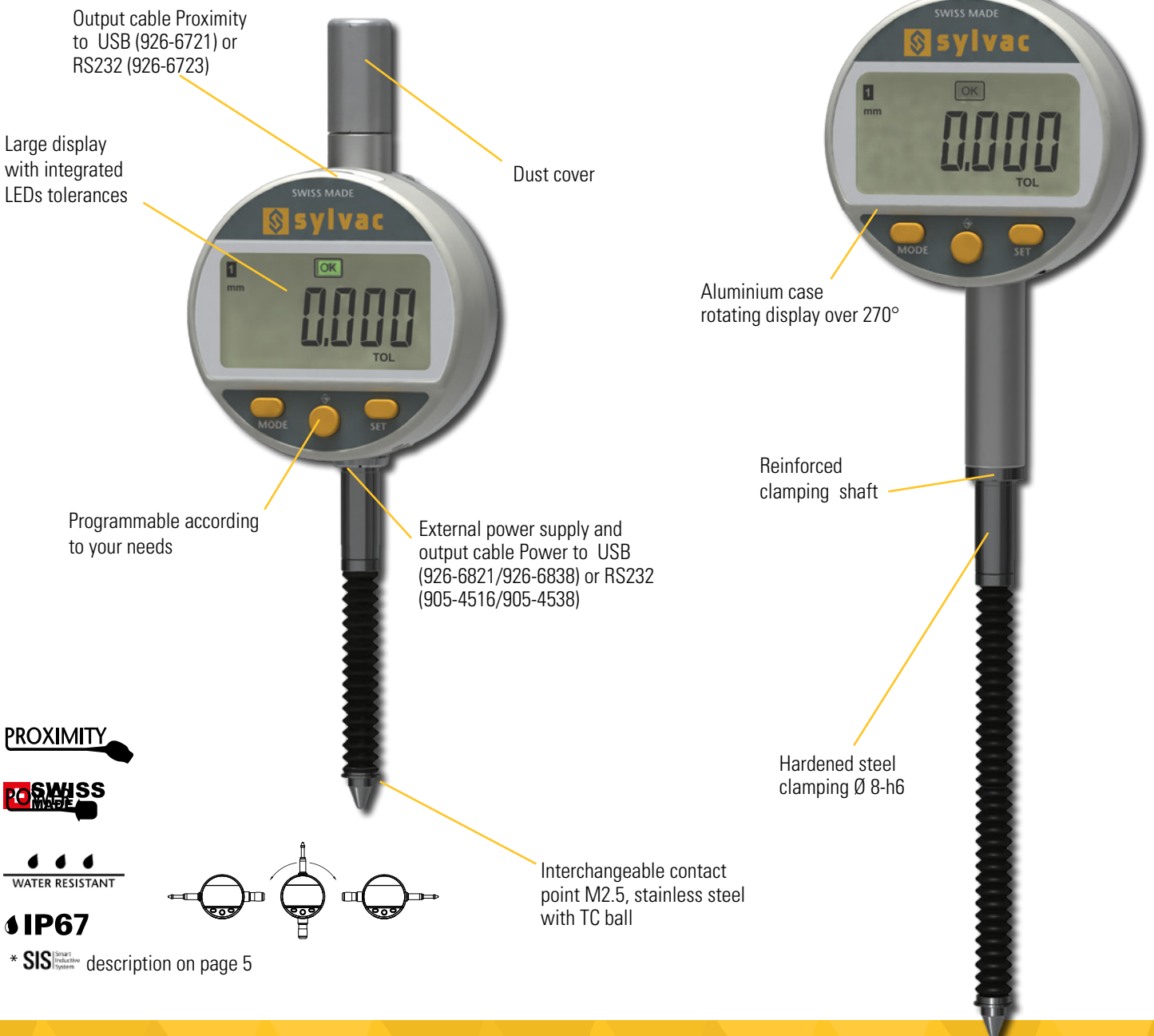

PROXIMITY

PO SWISS MADE

WATER RESISTANT

IP67

* SIS description on page 5

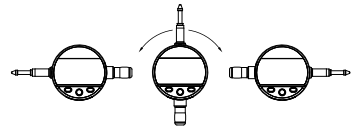

Interchangeable contact point M2.5, stainless steel with TC ball



Digital indicators

S_Dial WORK

DIMENSIONAL DRAWINGS

ADVANCED IP67

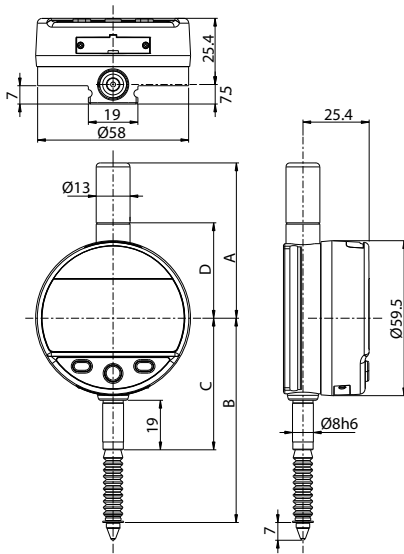

P 12.5-25 mm

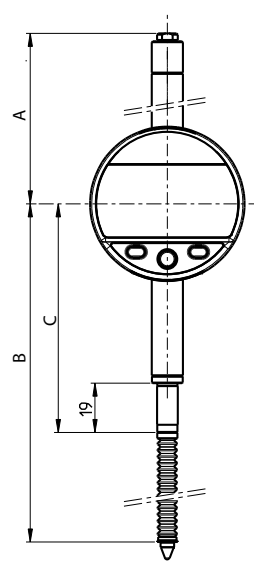

P 50 mm

TECHNICAL SPECIFICATIONS

		805-5305	805-5505	805-5625
Measuring range	mm	12.5	25	50
Resolution	mm	0.001	0.001	0.001
Max. Error fe	µm	3	4	5
Repeatability	µm	2		
IP rating		IP67		
A	mm	59.6	85.4	104.4
B	mm	78.4	99.7	175.3
C	mm	50.5	50.5	88
D	mm	36.6	49.4	-
Output data		USB / RS232		
Programmable by PC		●		
Standard functions (customized by PC)		mm/inch, ref I/II, preset (max 999.999) min/max/delta, tolerances, resolution, direction of measurement, multiplication factor, automatic or manual switch off, key lock		

STANDARD DELIVERY

- Instrument according to technical specifications
- Lithium battery CR2032 included
- Instruction manual
- Calibration certificate for instruments 0.001 mm

MEASURING FORCE

		P 12.5	P 25	P 50
Standard	N	0.7 – 1.4	0.65 – 1.8	0.9 – 2.8
Low ²⁾	N	---	---	---
High ²⁾	N	---	---	---

Tolerance ± 20%, spindle in outgoing measurement position.
²⁾ on request





Digital indicators

S_Dial WORK

DESCRIPTION

SMART

- Robust digital comparator with Ø 59.5 mm housing rotatable by 270°.
- Large display resolution 0.001 mm
- Integrated Bluetooth® system
- Large display with colour LED tolerance status indication
- Three buttons, including the central button with selectable favourite function
- Wide range of functions, including MIN/MAX/DELTA
- Proximity» and «Power» data outputs allowing the instrument to be used without batteries when connected by this cable.
- Measuring range selectable: 12.5, 25, 50 and 100 mm
- Protection class IP54

B

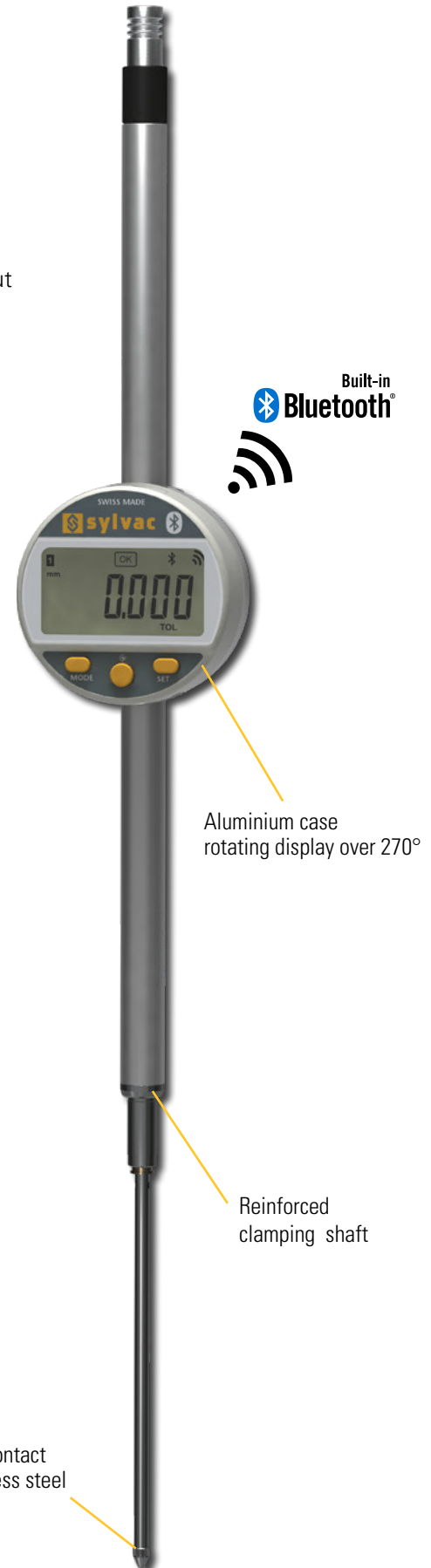
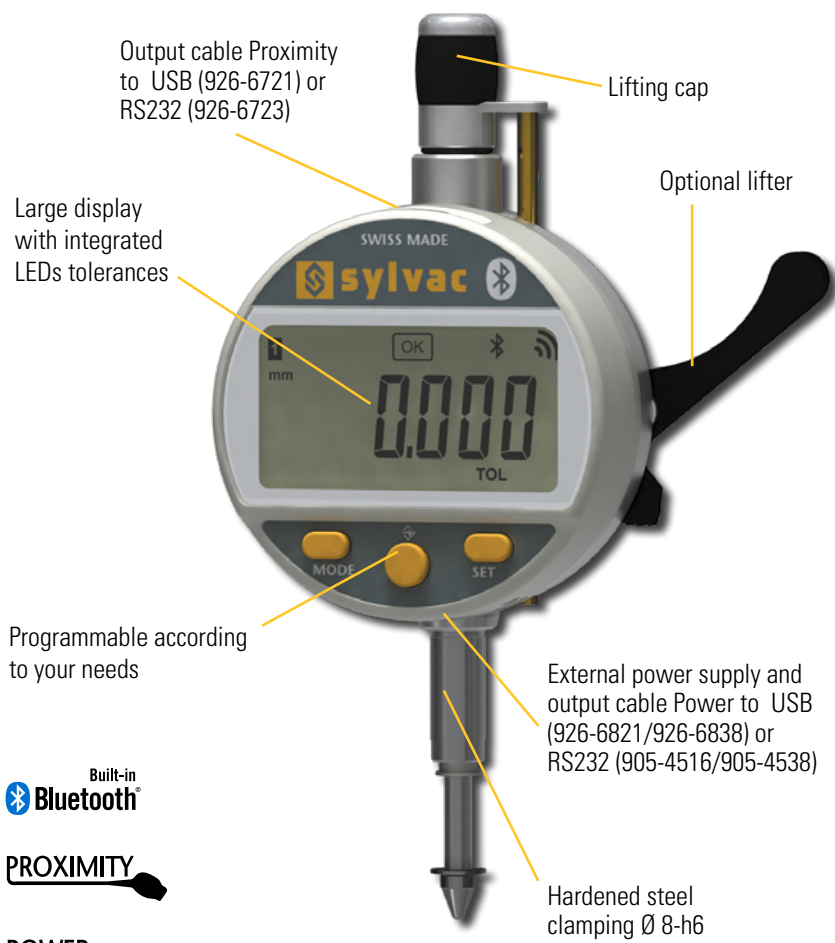

Built-in Bluetooth®

PROXIMITY

POWER

SWISS MADE

WATER RESISTANT

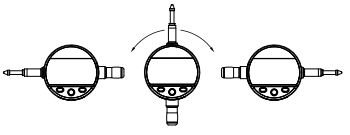

* SIS description on page 5



Digital indicators

S_Dial WORK

DIMENSIONAL DRAWINGS

SMART

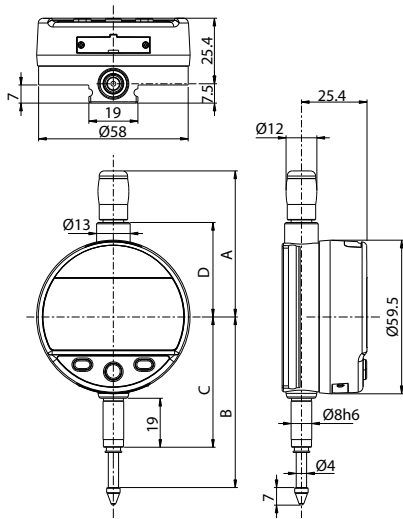

S 12.5 - 25

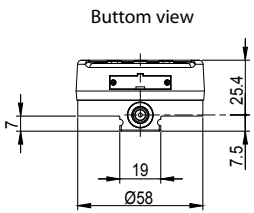
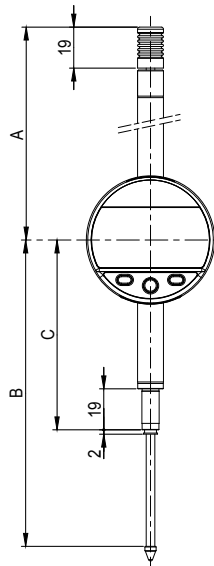

S 50 - 100

TECHNICAL SPECIFICATIONS

		805-6301	805-6501	805-6621	805-6661
Measuring range	mm	12.5	25	50	100
Resolution	mm	0.001	0.001	0.001	0.001
Max. Error fe	µm	3	4	5	6
Repeatability	µm	2			
IP rating		IP54			
A	mm	56.7	69.4	121	172
B	mm	66.1	78.5	142	244
C	mm	50.5	50.5	88	139
D	mm	36.6	49.4	-	-
Output data		USB / RS232 / Bluetooth® wireless technology*			
Programmable by PC		●			
Standard functions (customized by PC)		mm/inch, ref I/II, preset (max 999.999) min/max/delta, tolerances, resolution, direction of measurement, multiplication factor, automatic or manual switch off, key lock			

¹⁾ ± 1 digit

*** Up to 8 instruments connected per dongle #981-7100**

STANDARD DELIVERY

- Instrument according to technical specifications
- Lithium battery CR2032 included
- Instruction manual
- Calibration certificate for instruments 0.001 mm

MEASURING FORCE

		12.5	25	50	100
Standard	N	0.65 - 0.90	0.65 - 1.15	1.1 - 2.6	1.8 - 3.8
Low ²⁾	N	0.4 - 0.55	0.45 - 0.9	---	---
High ²⁾	N	1.0 - 1.6	0.9 - 1.8	---	---

Tolerance ± 20%, spindle in outgoing measurement position.
²⁾ on request

B



Digital indicators

S_Dial WORK

DESCRIPTION

ANALOG & ANALOG SMART

- Robust digital comparator with Ø 59.5 mm housing rotatable by 270°.
- Integrated Bluetooth® system on Smart model
- Large display with 0.001 mm resolution and colour LED tolerance status indication
- Analogue display with selectable scale (from 0.2 µm per division)
- Three buttons, including the central button with selectable favourite function
- Wide range of functions, including MIN/MAX/DELTA
- Proximity» and «Power» data outputs allowing the instrument to be used without batteries when connected by this cable.
- Measuring range selectable: 12.5 and 25 mm
- Special low or high pressure versions available on request
- Protection class IP54

B

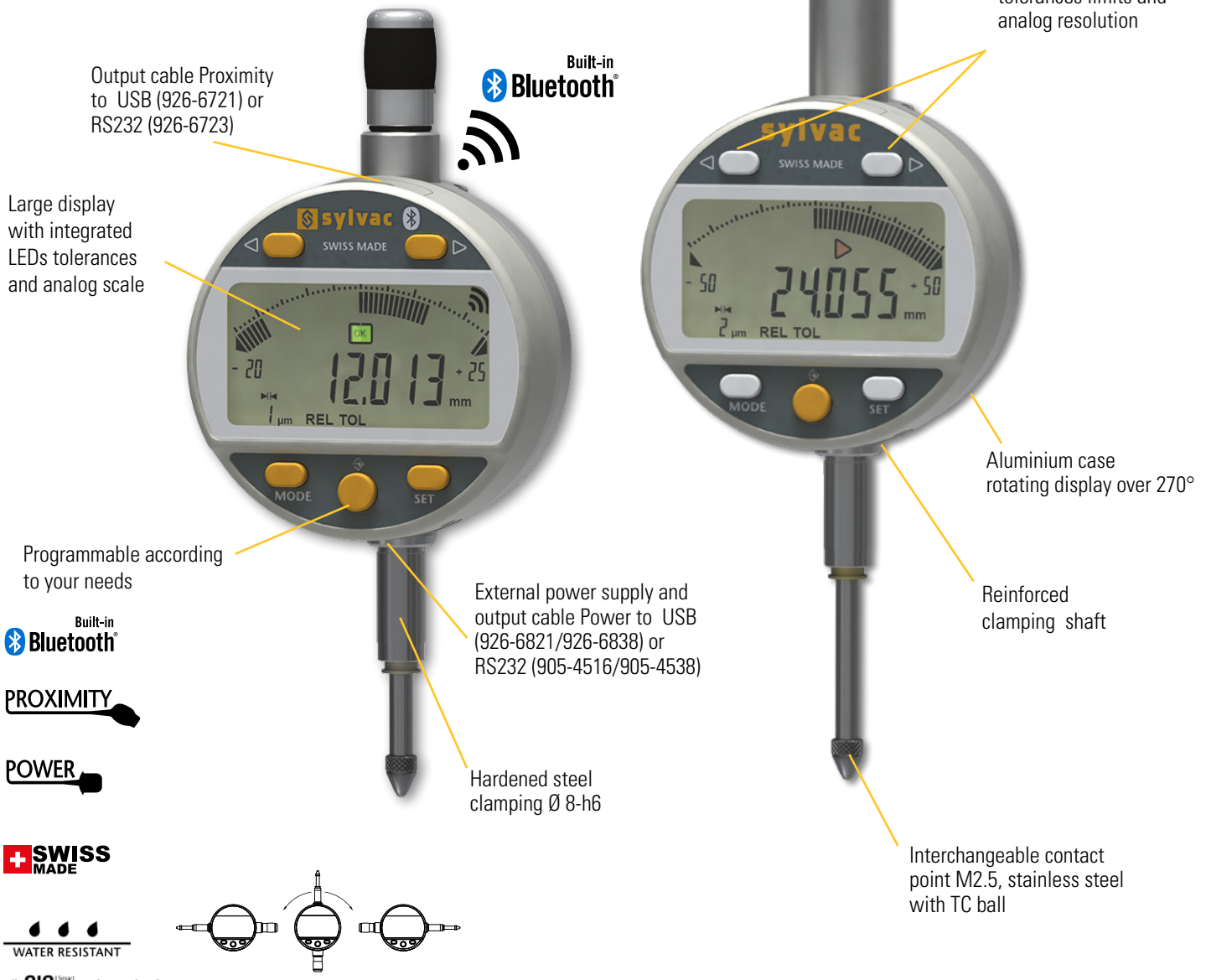

Built-in Bluetooth®

PROXIMITY

POWER

SWISS MADE

WATER RESISTANT

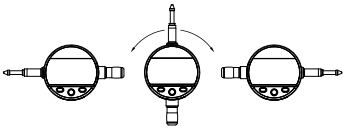



Digital indicators

S_Dial WORK

DIMENSIONAL DRAWINGS

ANALOG & ANALOG SMART

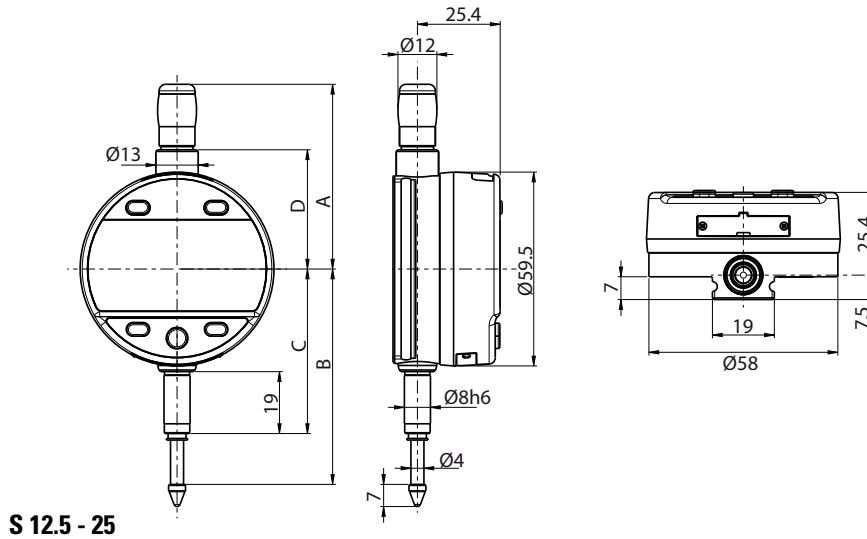

TECHNICAL SPECIFICATIONS

		805-5307	805-5507	805-6308
Measuring range	mm	12.5	25	12.5
Resolution	mm	0.001		
Max. Error fe	µm	3	4	3
Repeatability	µm	2		
IP rating		IP54		
A	mm	56.7	69.4	56.7
B	mm	66.1	78.5	66.1
C	mm	50.5	50.5	50.5
D	mm	36.6	49.4	36.6
Output data		USB / RS232		USB / RS232 / Bluetooth® *
Programmable by PC		●		
Standard functions (customized by PC)		mm/inch, preset (max 999.999) min/max/delta, tolerances, resolution, direction of measurement, multiplication factor, automatic or manual switch off, key lock		

¹⁾ ± 1 digit

*** Up to 8 instruments connected per dongle #981-7100**

STANDARD DELIVERY

MEASURING FORCE

- Instrument according to technical specifications
- Lithium battery CR2032 included
- Instruction manual
- Calibration certificate

		S 12.5	S 25
Standard	N	0.65 - 0.90	0.65 - 1.15
Low ²⁾	N	0.4 - 0.55	0.45 - 0.9
High ²⁾	N	1.0 - 1.6	0.9 - 1.8

Tolerance ± 20%, spindle in outgoing measurement position.

²⁾ on request

Digital indicators

S_Dial WORK

DESCRIPTION

CBG

- Special version for cylindrical bore gauges
- Data output Power, Proximity & Bluetooth®
- Introduction of the Preset value on the saved Min value
- Quick measure of the reversal point
- Robust construction
- Water and coolant resistant
- Broad choice of functions (MIN/MAX/DELTA, TOL, PRESET, AUTO OFF, etc.)
- Automatic wake-up and sleeping mode, Absolute System S.I.S*
- Maximum error of 3 µm



B

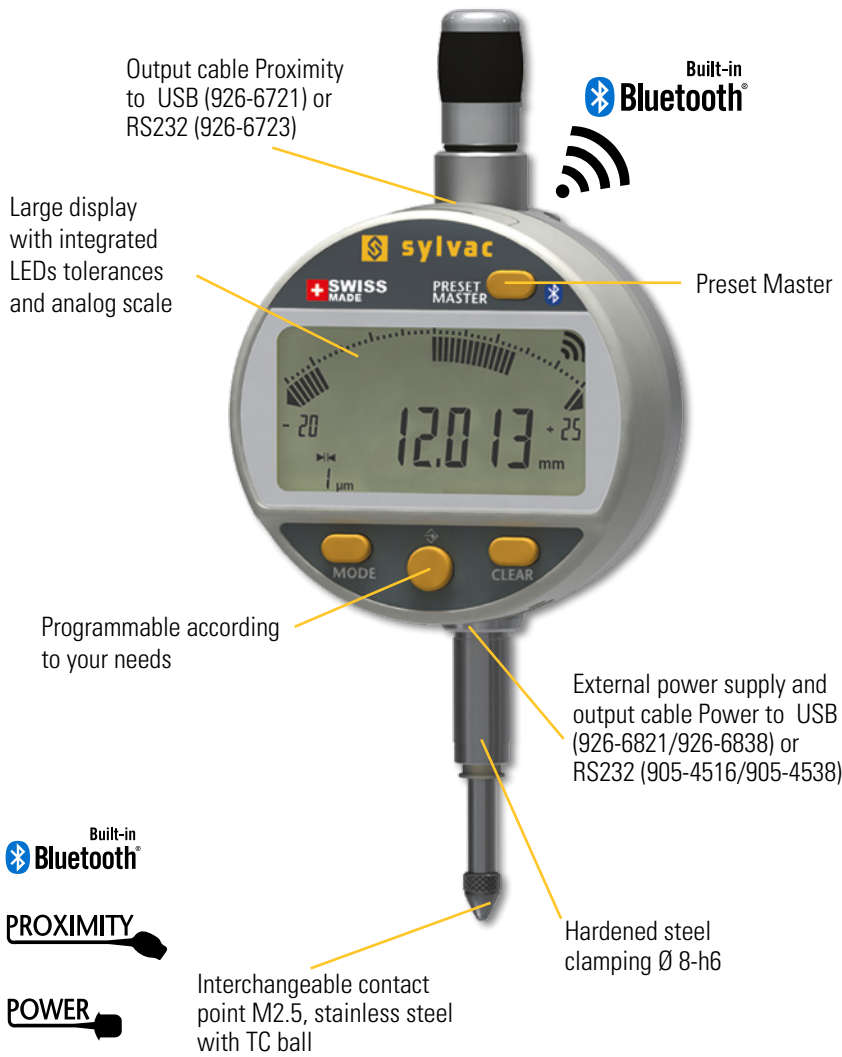

Lifting cap
Aluminium case rotating display over 270°



Built-in Bluetooth

PROXIMITY

POWER

SWISS MADE

WATER RESISTANT

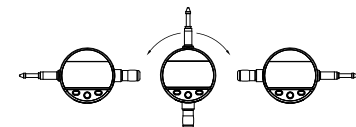

* SIS description on page 5



Digital indicators

S_Dial WORK

DIMENSIONAL DRAWINGS

CBG

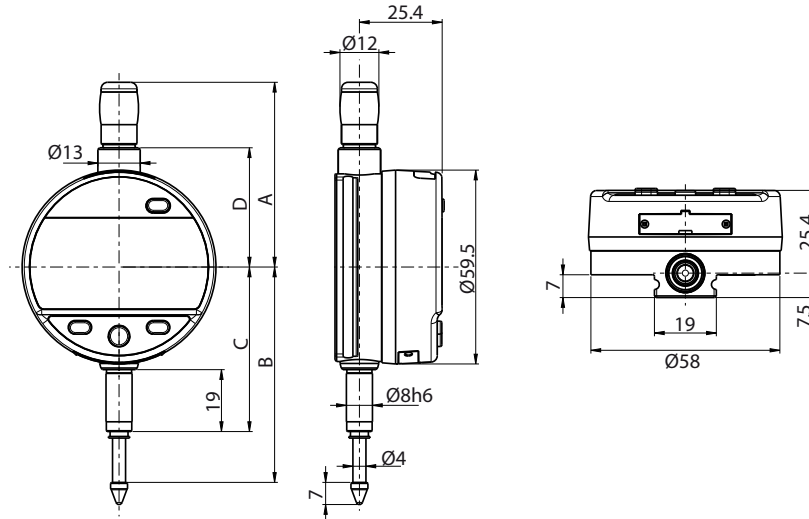

TECHNICAL SPECIFICATIONS

		805-6317
Measuring range	mm	12.5
Resolution	mm	0.001
Max. Error fe	µm	3
Repeatability	µm	2
IP rating		IP54
A	mm	56.7
B	mm	66.1
C	mm	50.5
D	mm	36.6
Output data	USB / RS232 / Bluetooth® wireless technology*	
Programmable by PC	●	
Standard functions (customized by PC)	mm/inch, preset (max 999.999) min/max/delta, tolerances, resolution, multiplication factor, automatic or manual switch off	

¹⁾ ± 1 digit

*** Up to 8 instruments connected per dongle #981-7100**

STANDARD DELIVERY

MEASURING FORCE

- Instrument according to technical specifications
- Lithium battery CR2032 included
- Instruction manual
- Calibration certificate

		S 12.5
Standard	N	0.65 - 0.90
Low ²⁾	N	0.4 - 0.55
High ²⁾	N	1.0 - 1.6

Tolerance ± 20%, spindle in outgoing measurement position.
²⁾ on request



Digital indicators

S_Dial WORK

DESCRIPTION

NANO & NANO SMART

- Robust digital comparator with \varnothing 59.5 mm housing rotatable by 270°.
- Integrated Bluetooth® system on Smart model
- Large display resolution 0.0001 mm (0.1 μ m) with tolerance status indication by colour LEDs
- High accuracy and repeatability
- Three buttons, including the central button with selectable favourite function
- Wide range of functions, including MIN/MAX/DELTA
- Proximity» and «Power» data outputs allowing the instrument to be used without batteries when connected by this cable.
- Measuring range selectable: 12.5 and 25 mm
- Special low or high pressure versions available on request
- Protection class IP54

B

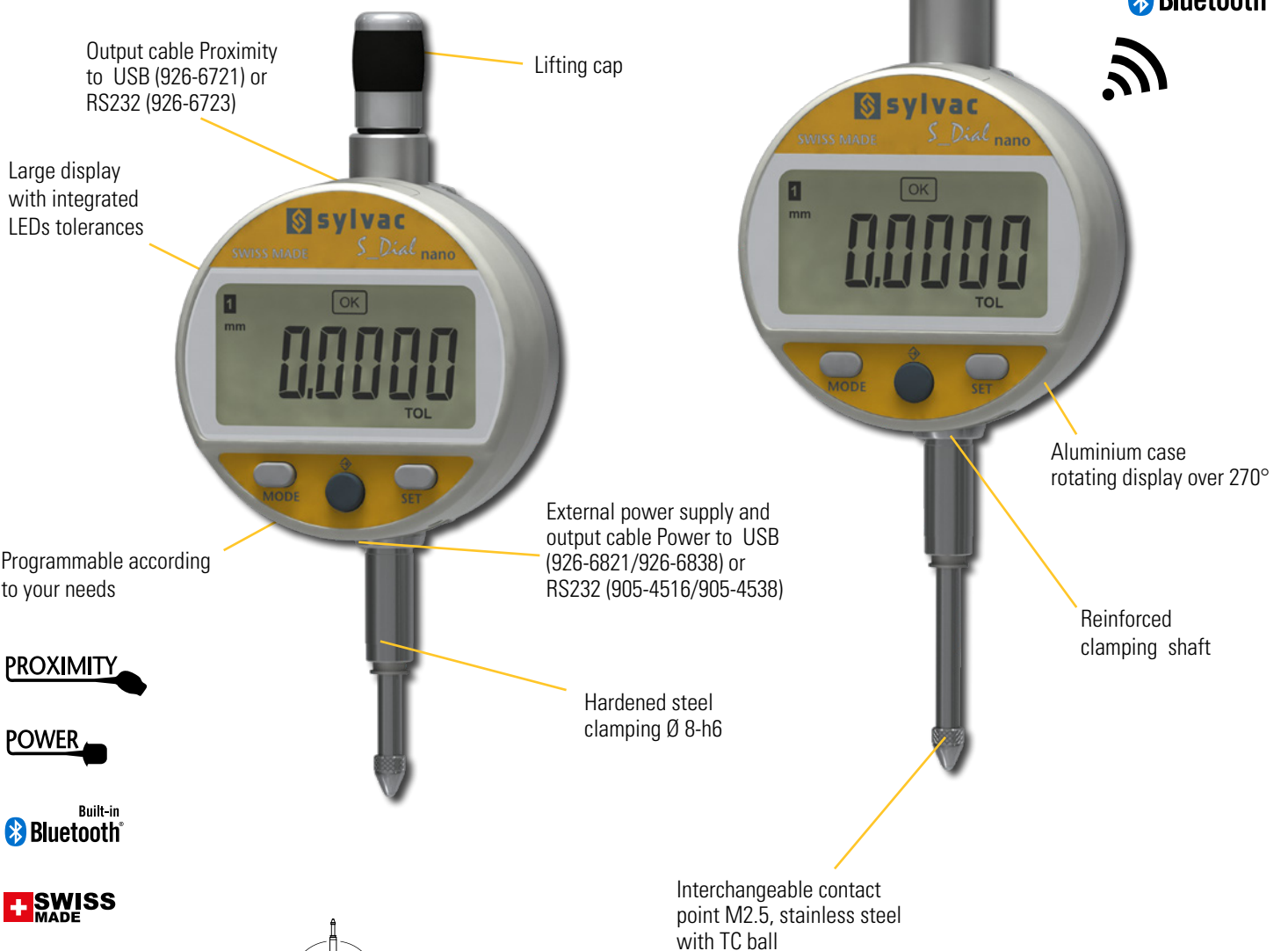

PROXIMITY

POWER

Built-in **Bluetooth**

SWISS MADE

WATER RESISTANT

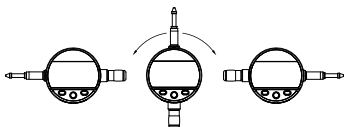

* SIS description on page 5

Max error 1.2 μ m
Repeatability 0.3 μ m



Digital indicators

S_Dial WORK

DIMENSIONAL DRAWINGS

NANO & NANO SMART

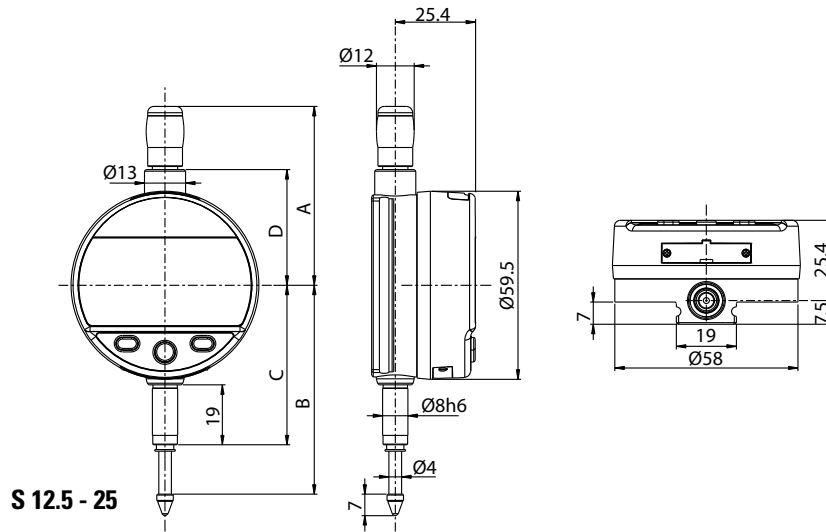

S 12.5 - 25

TECHNICAL SPECIFICATIONS

		805-5306	805-5506	805-6306	805-6506
Measuring range	mm	12.5	25	12.5	25
Resolution	mm	0.0001	0.0001	0.0001	0.0001
Max. Error fe	µm	1.2	1.6	1.2	1.6
Repeatability	µm	0.3			
IP rating		IP54			
A	mm	56.7	69.4	56.7	69.4
B	mm	66.1	78.5	66.1	78.5
C	mm	50.5	50.5	50.5	50.5
D	mm	36.6	49.4	36.6	49.4
Output data		USB / RS232		USB / RS232 / Bluetooth® wireless technology*	
Programmable by PC		●			
Standard functions (customized by PC)		mm/inch, ref I/II, preset (max 999.999) min/max/delta, tolerances, resolution, direction of measurement, multiplication factor, automatic or manual switch off, key lock			

*** Up to 8 instruments connected per dongle #981-7100**

STANDARD DELIVERY

MEASURING FORCE

- Instrument according to technical specifications
- Lithium battery CR2032 included
- Instruction manual
- Calibration certificate

		S 12.5	S 25
Standard	N	0.65 - 0.90	0.65 - 1.15
Low ²⁾	N	0.4 - 0.55	0.45 - 0.9
High ²⁾	N	1.0 - 1.6	0.9 - 1.8

Tolerance ± 20%, spindle in outgoing measurement position.
²⁾ on request





Digital indicators

S_Dial WORK

DESCRIPTION

ANALOG NANO SMART

- Robust digital comparator with \varnothing 59.5 mm housing rotatable by 270°.
- Integrated Bluetooth® system on Smart model
- Large display resolution 0.0001 mm (0.1 μ m) with tolerance status indication by colour LEDs
- High accuracy and repeatability
- Five buttons, including the central button with selectable favourite function
- Wide range of functions, including MIN/MAX/DELTA
- Proximity» and «Power» data outputs allowing the instrument to be used without batteries when connected by this cable.
- Measuring range selectable: 12.5 and 25 mm
- Special low or high pressure versions available on request
- Protection class IP54

B

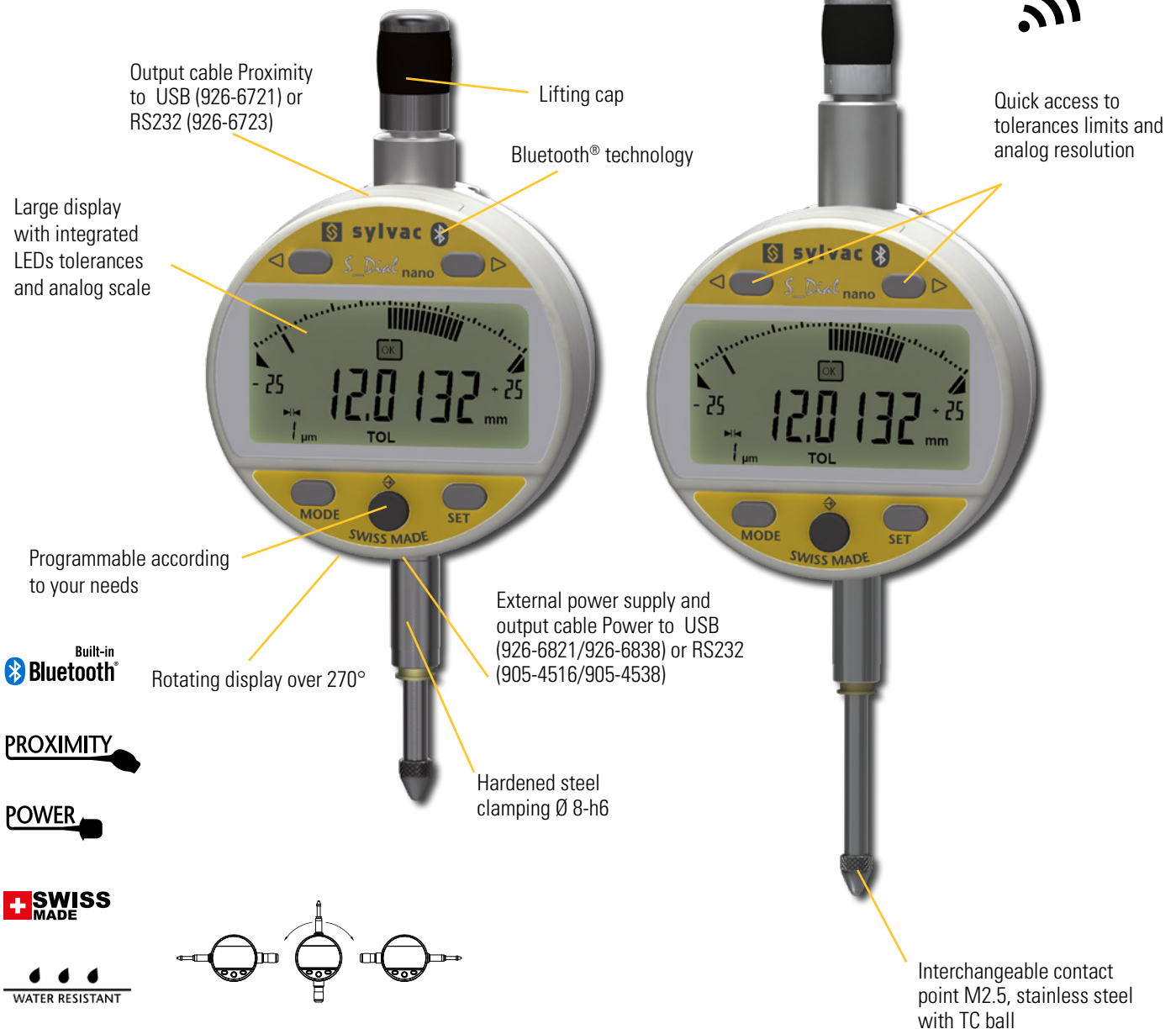

* SIS description on page 5



Digital indicators

S_Dial WORK

DIMENSIONAL DRAWINGS

ANALOG NANO SMART

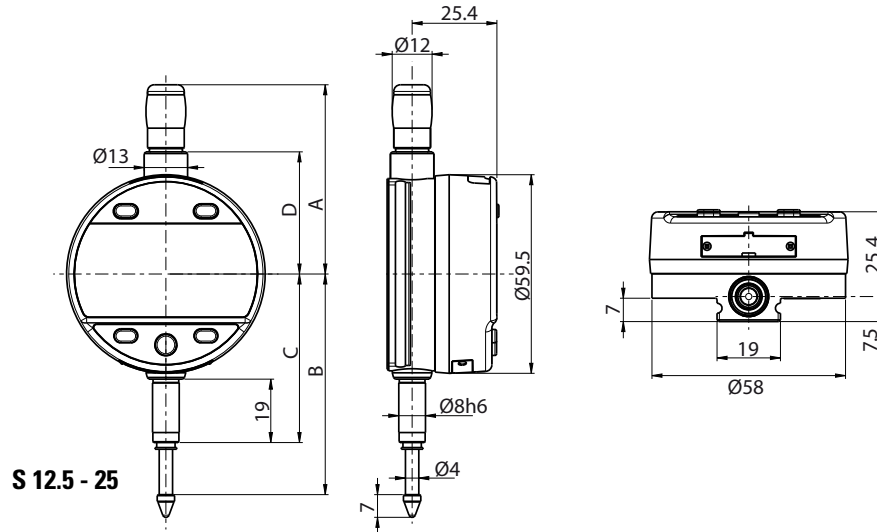

TECHNICAL SPECIFICATIONS

		805-6307	805-6507
Measuring range	mm	12.5	25
Resolution	mm	0.0001	
Max. Error fe	µm	1.2	1.6
Repeatability	µm	0.3	
IP rating		IP54	
A	mm	56.7	69.4
B	mm	66.1	78.5
C	mm	50.5	50.5
D	mm	36.6	49.4
Output data	USB / RS232 / Bluetooth® wireless technology*		
Programmable by PC	●		
Standard functions (customized by PC)	mm/inch, preset (max 99.9999 or 999.999) min/max/delta, tolerances, resolution, direction of measurement, multiplication factor, automatic or manual switch off, key lock		

* Up to 8 instruments connected per dongle #981-7100

STANDARD DELIVERY

MEASURING FORCE

- Instrument according to technical specifications
- Lithium battery CR2032 included
- Instruction manual
- Calibration certificate

		S 12.5	S 25
Standard	N	0.65 - 0.90	0.65 - 1.15
Low ²⁾	N	0.4 - 0.55	0.45 - 0.9
High ²⁾	N	1.0 - 1.6	0.9 - 1.8

Tolerance ± 20%, spindle in outgoing measurement position.
²⁾ on request

Digital indicators

S_Dial WORK

DESCRIPTION

PLC

B

- Robust digital comparator with Ø 59.5 mm housing rotatable by 270°.
- Instrument for automation and robotics
- Large display resolution 0.01 mm or 0.001 mm with tolerance status indication by colour LEDs
- Three buttons, including the central button with selectable favourite function
- Wide range of functions, including MIN/MAX/DELTA
- Data outputs «Open connector» for using the instrument without batteries (powered by the device) and «Proximity».
- Selection of the communication protocol to be chosen between ASCII, MODBUS and ORBIT
- Measuring range selectable: 12.5 and 25 mm
- Special low or high pressure versions available on request
- Protection IP54 for the 0.01 mm resolution version and IP67 for the 0.001 mm resolution version

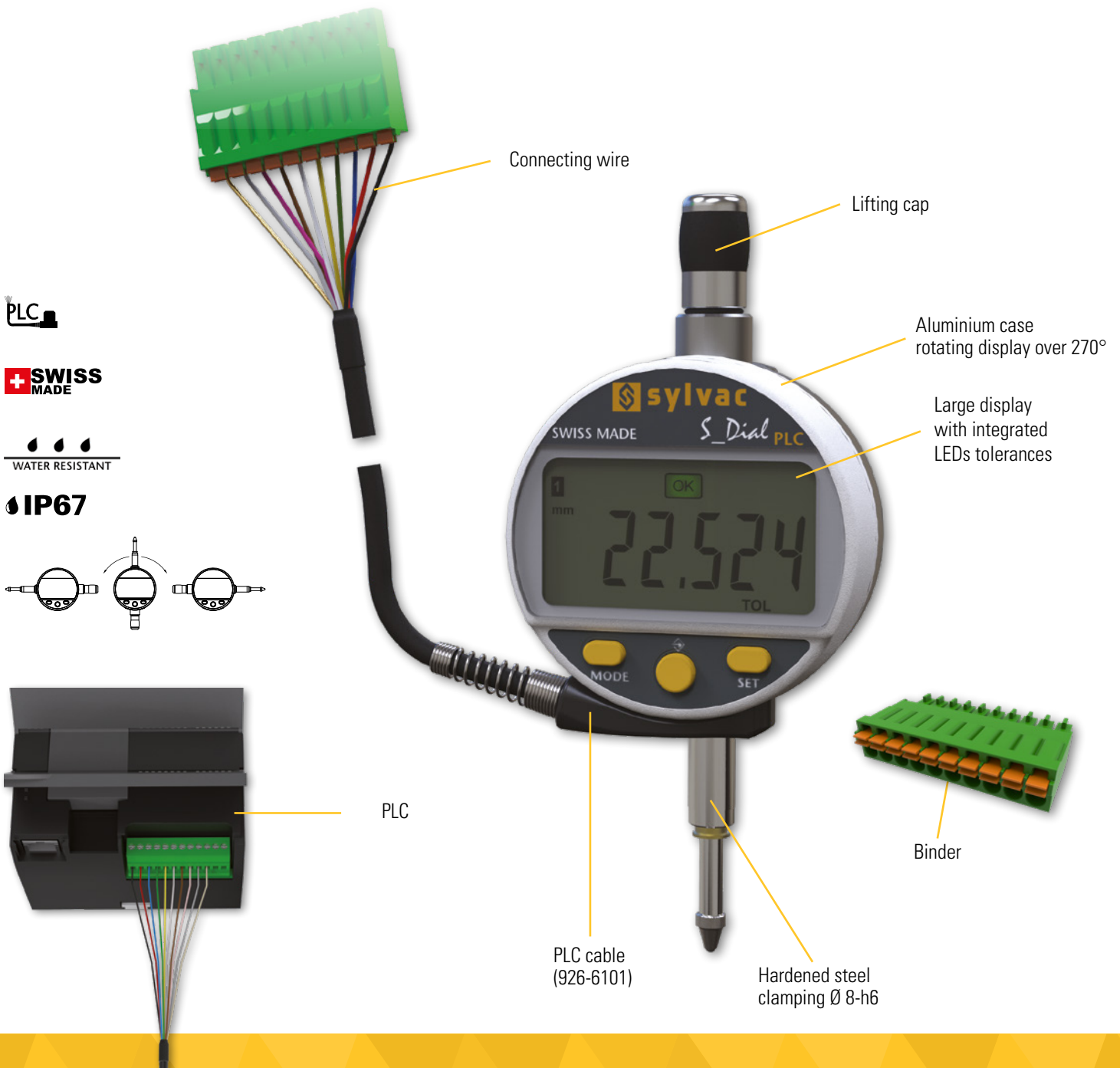



Digital indicators

S_Dial WORK

DIMENSIONAL DRAWINGS

PLC

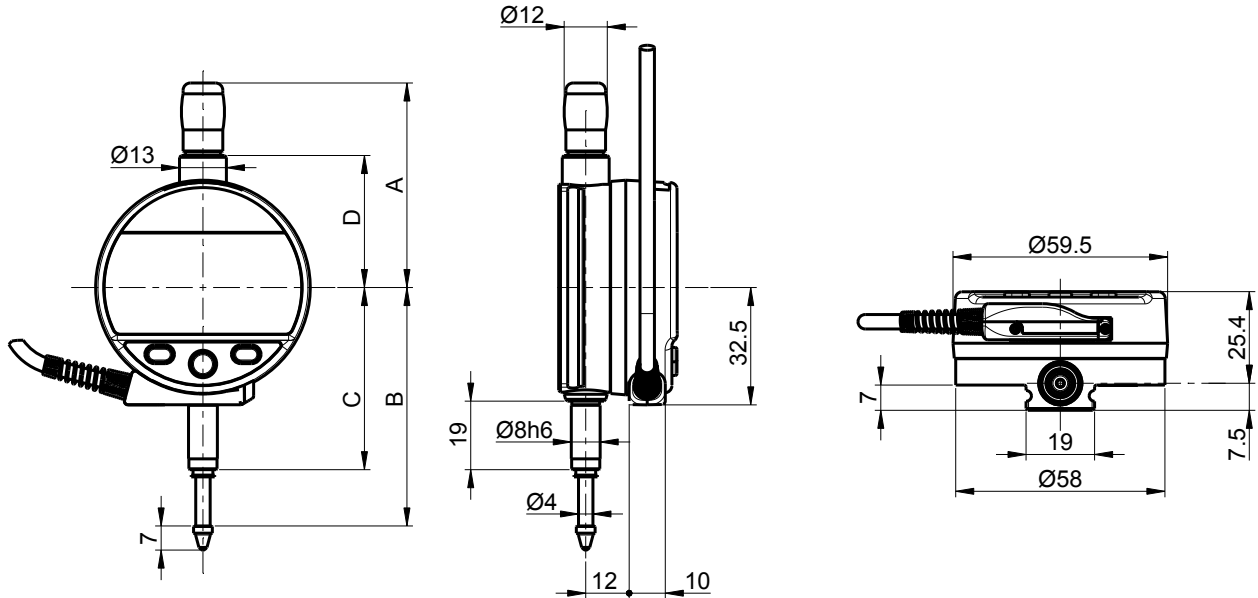

B

TECHNICALS SPECIFICATIONS

		805-7301	805-7201	805-7501	805-7401
Measuring range	mm	12.5	12.5	25	25
A	mm	56.7		69.4	
B	mm	66.1		78.5	
C	mm	50.5		50.5	
D	mm	36.6		49.4	
Resolution	mm	0.001	0.01	0.001	0.01
Max. Error fe	µm	4	10	5	10
Repeatability	µm	2			
Output data		PLC cable / RS232 (Proximity) and RS485 (cable) compatible			
Data bus		RS485 compatible / Charge 1/256 (Protocole MODBUS, ASCII or ORBIT)			
Measuring force	N	0.65 - 0.9		0.65 - 1.15	
IP rating		IP67	IP54	IP67	IP54
Clamping		Ø8h6, interchangeable anvil probe M2.5			
Standard functions (customizable by PC)		mm/inch, ref I/II, preset (max 999.999) min/max/delta, tolerances, resolution, measuring direction, multiplier, keylock			

INSTRUMENT DE BASE

- Instrument according to technical specifications
- Manual
- PLC cable + binder included
- Calibration certificate

Digital indicators

S_Dial PRO

DESCRIPTION

SMART

B

- Robust digital comparator with Ø 59.5 mm housing rotatable by 270°.
- Large display resolution 0.0001 mm (0.1 µm) with tolerance status indication by colour LEDs
- High accuracy over the entire measuring range thanks to an electronically corrected scale system with reference marks
- Measuring error less than 1.2 µm over 50 mm
- Three buttons, including the central button with selectable favourite function
- Wide range of functions, including MIN/MAX/DELTA
- Bluetooth®, Proximity» and «Power» data outputs allowing the instrument to be used without batteries when connected by this cable.
- Available with a fixing diameter of 8 mm and 25 mm for some models
- Measuring range of your choice: 25, 50 and 100 mm
- Available in standard pressure or low-pressure version without return spring for vertical use.
- Protection class IP51



Large display with integrated LEDs tolerances

Aluminium case rotating display over 270°

Customizable button

Clamping ø25 - g7
Stainless steel chrome

Output cable Proximity to USB (926-6721) or RS232 (926-6723)

50 mm

External power supply and output cable Power to USB (926-6821/926-6838) or RS232 (905-4516/905-4538)

Aluminium tube

Clamping ø8 - h6
Stainless hardened steel

Lifter



100 mm

25 mm



Digital indicators

S_Dial PRO

DIMENSIONAL DRAWINGS

SMART

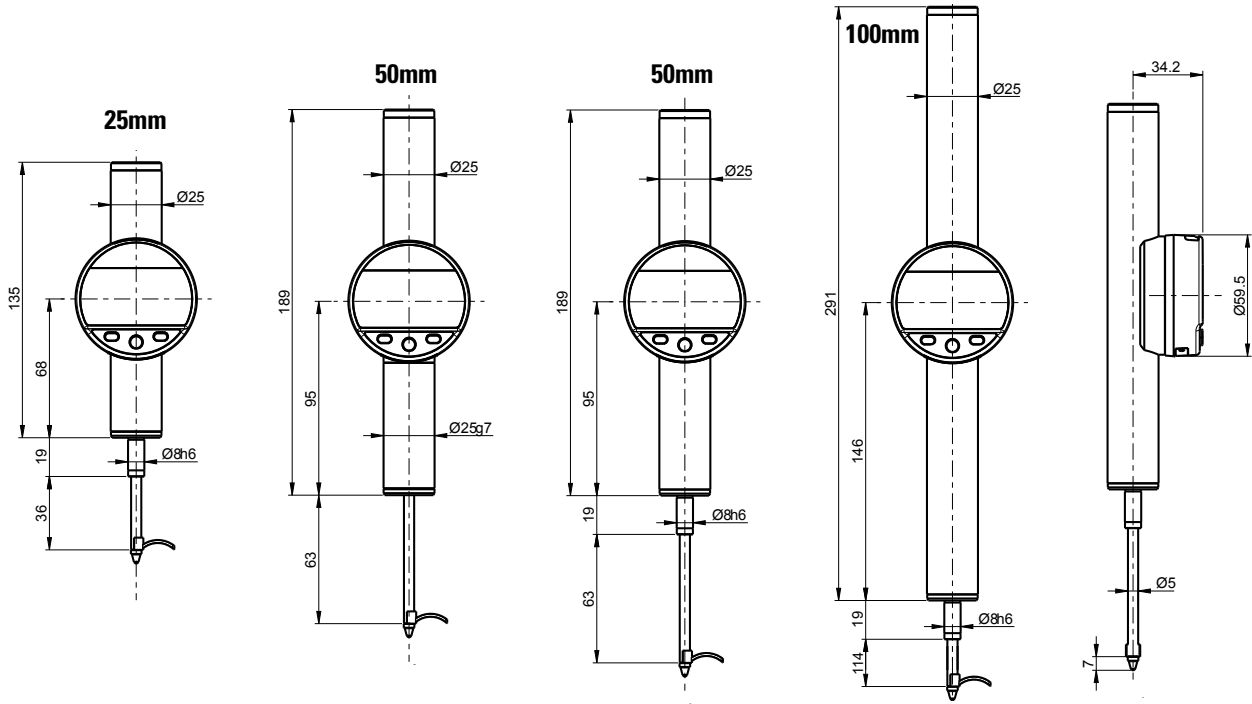

TECHNICALS SPECIFICATIONS

		805-8501	805-8502	805-8601	805-8701	805-8602	805-8702	805-8661
Measuring range	mm	25		50			100	
Resolution	mm	0.0001						
Max. Error fe	µm	1.0		1.2			1.8	
Repeatability	µm	0.2						
Output data		USB / RS232 / Bluetooth® wireless technology*						
Programmable by PC		●						
Clamping		ø8 h6			ø25 g7		ø8 h6	
Spring		●	1)	●	1)	●	1)	●
Measuring force	N	0.75 - 1.00 ²⁾	0.30 ²⁾	0.85 - 1.2 ²⁾	0.40 ²⁾	0.85 - 1.2 ²⁾	0.40 ²⁾	0.90 - 1.30 ²⁾
IP rating		IP51						
Standard functions (customizable by PC)		mm/inch, ref I/II, preset (max 99.9999) min/max/delta, tolerances, resolution, measuring direction, multiplier, automatic extinction/manual, keylock						

¹⁾ Model without spring : Constant measuring force, use only in a vertical position

²⁾ The values agree within ± 20% (vertical down, measuring rod outgoing)

*** Up to 8 instruments connected per dongle #981-7100**

INSTRUMENT DE BASE

- Instrument according to technical specifications
- Lithium battery CR2032 included
- Lifter included
- Manual
- Calibration certificate

B

Digital indicators

S_Dial

APPLICATIONS

B



Measurement of a span with S_Dial WORK equipped with measuring ball probe 905-2207



S_Dial WORK CBG measuring with bore gauge system



S_Dial WORK mounted on a Sylvac PS15 bench



S_Dial WORK Smart working in duplex mode and connected to D300S to measure concentricity, roundness, etc.



S_Dial WORK PLC connected to a PLC



S_Dial WORK Analog used on bore gauge system



Indicators with Bluetooth® Wireless technology on a 4 points jig



Indicators with Bluetooth® Wireless technology on an iPad through the Sylvac BT Smart App



S_Dial PRO on ceramic stand



Digital indicators

S_Dial

LIFTING DEVICES



Lower lifting lever, type 905-4214

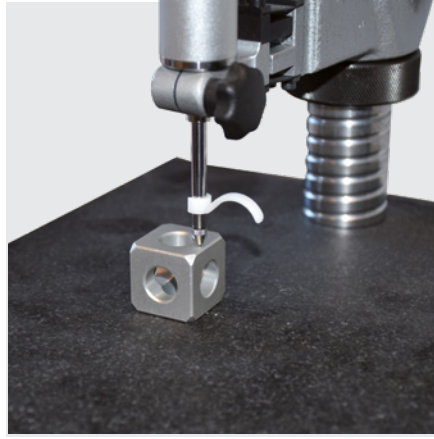

Lifting device on S_Dial PRO Basic



Upper lifting device type 905-4215

B



Pneumatic lifting device type 905-2218



Vacuum lifting device type 905-2220



Lifting device with photo-cable type 905-2216



Lifting device type 905-2214



Lifting device on S_Dial WORK Smart



Upper lifting lever type, 905-2215



Digital indicators

S_Dial

ACCESSORIES

Contact points M2.5

B

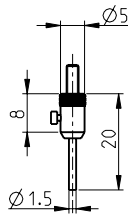
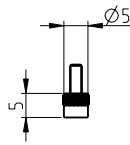
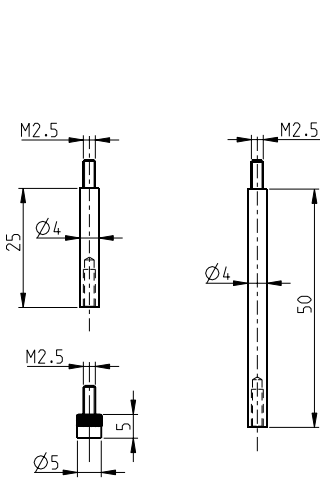

905-2201 (carbide)

905-2202

905-2203

S_Dial Mini
 S_Dial TEST (805-4321)
 S_Dial TEST (805-4322)
 S_Dial TEST (805-4323)
 S_Dial WORK
 12,5 - 25 mm
 S_Dial WORK
 50 - 150 mm
 S_Dial PRO

•				•	•	•
---	--	--	--	---	---	---

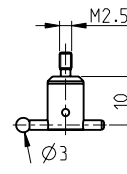
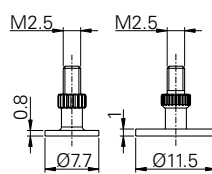
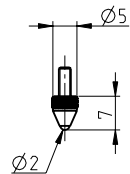

905-2206

905-2204

905-2205

905-2207

•				•	•	•
---	--	--	--	---	---	---

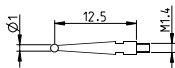

905-2240

Short stylus, TC ball

	•		•			
--	---	--	---	--	--	--

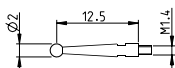

905-2241

Short standard stylus, TC ball

	•		•			
--	---	--	---	--	--	--

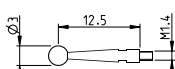

905-2242

Short stylus, TC ball

	•		•			
--	---	--	---	--	--	--

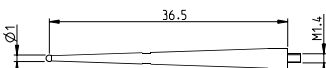

905-2243

Long stylus, TC ball

		•	•			
--	--	---	---	--	--	--

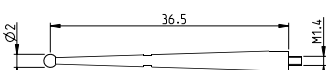

905-2244

Long standard stylus, TC ball

		•	•			
--	--	---	---	--	--	--

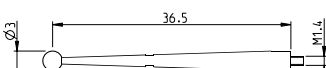

905-2245

Long stylus, TC ball

		•	•			
--	--	---	---	--	--	--



Digital indicators

S_Dial

ACCESSORIES

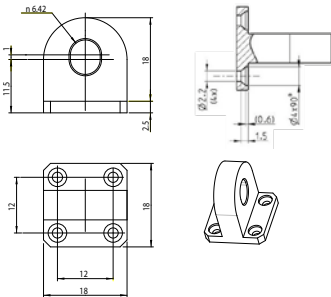
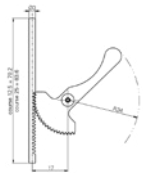
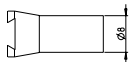
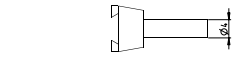

		S_Dial Mini	S_Dial TEST	S_Dial WORK 12,5 - 25 mm	S_Dial WORK 50 - 150 mm
905-2246	Clamping stem	•	•		
905-2247	Clamping stem	•	•		
905-2248	Spanner for probe		•		
805-0214	Lifting device, range 12.5mm			• 1)	
805-0215	Lifting device, range 25mm			• 1)	
805-0213	Lug back (delivered with 4 screws M2x4 DIN 963A)			• 1)	• 1)
905-2231	Sleeve Ø8 --> 10mm with locking screw	•	•	•	•
905-4212	Screwdriver for S_Dial MINI & TEST	•	•		

B

¹⁾ Except S_Dial WORK Basic

Digital indicators

S_Dial

ACCESSORIES

B

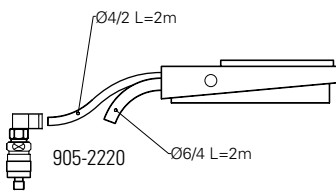
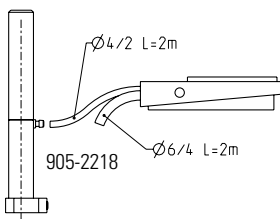
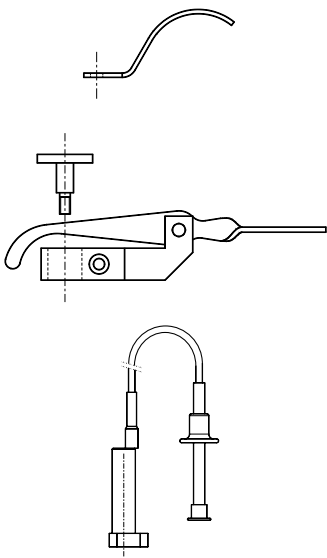

		S_Dial Mini	S_Dial TEST	S_Dial WORK 12,5 - 25 mm	S_Dial WORK 50 - 150 mm	S_Dial PRO
905-2214	Lifting device	•		•	•	•
905-2215	Upper lifting device			•		
905-2216	Lifting device with photo-cable			•		
905-2218	Pneumatic lifting device with foot pedal			•		
905-2217	Lifter only for 905-2218			•		
905-2219	Pneumatic foot pedal for 905-2218	•		•		
905-2220	Vacuum lifting device with foot pedal				•	
905-2227	Pressure controller				•	
905-2228	Vacuum foot pedal for 905-2220				•	



Digital indicators

S_Dial

ACCESSORIES

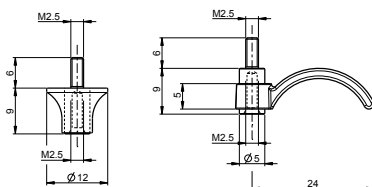
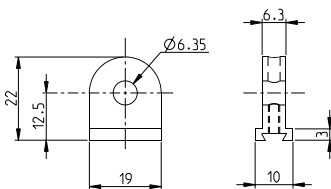
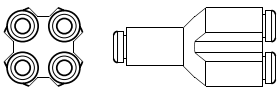
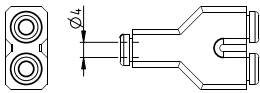
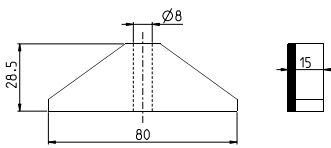
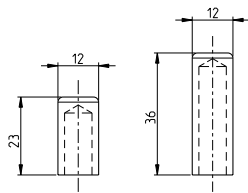

		S_Dial Mini	S_Dial TEST	S_Dial WORK 12,5 - 25 mm	S_Dial WORK 50 - 150 mm	S_Dial PRO
905-2221	Dust protection for indicator, range 12.5 mm			•		
905-2222	Dust protection for indicator, range 25 mm			•		
905-2223	Depth measuring base			•	•	
905-2261	Snap connector for pneumatic lifter x2	•		•	•	
905-2262	Snap connector for pneumatic lifter x4	•		•	•	
905-4211	Center lug back	•	•			
905-2224	Plastic lifting lever (bottom)	•		•	•	•
905-2225	Plastic lifting ring (bottom)	•		•	•	•

B

Digital indicators

S_Dial

ACCESSORIES

B

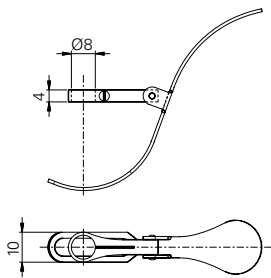

905-4214

Lower lifting device, range 12.5 mm

S_Dial Mini

S_Dial TEST

S_Dial WORK
12,5 - 25 mm

S_Dial WORK
50 - 150 mm

S_Dial WORK
PLC



1)

1)

1)

1)

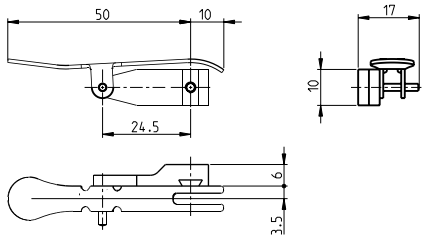

905-4215

Upper lifting device for S (Standard) execution

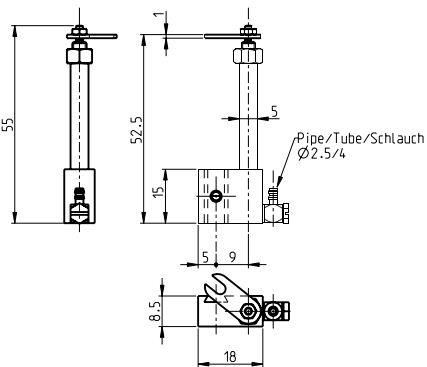

905-4217

Pneumatic lifting device for standard type

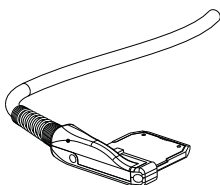

926-6101

Replacement cable for digital indicator PLC



¹⁾ used on range 20 mm max



Digital indicator testing stand M3

DESCRIPTION

- Set for the periodic calibration of analogue and digital comparators up to 50 mm stroke as well as for lever indicators
- Set consisting of the M3 bench that can be used vertically or horizontally, the reference instrument and the Sycopro II software integrating several international standards.
- Bench with rapid manual movement and fine final approach
- Available in 2 versions, with different reference instruments and different measuring ranges :
 - Set with capacitive touch probe paired with display unit, 10 and 25 mm (max. error 0.8 µm)
 - Set with precision dial gauge with integrated display, 25 and 50 mm (max. error 1.2 µm)
- Calibration according to the ABBE principle
- Real-time display of instrument status
- Creation of customised test certificates

B

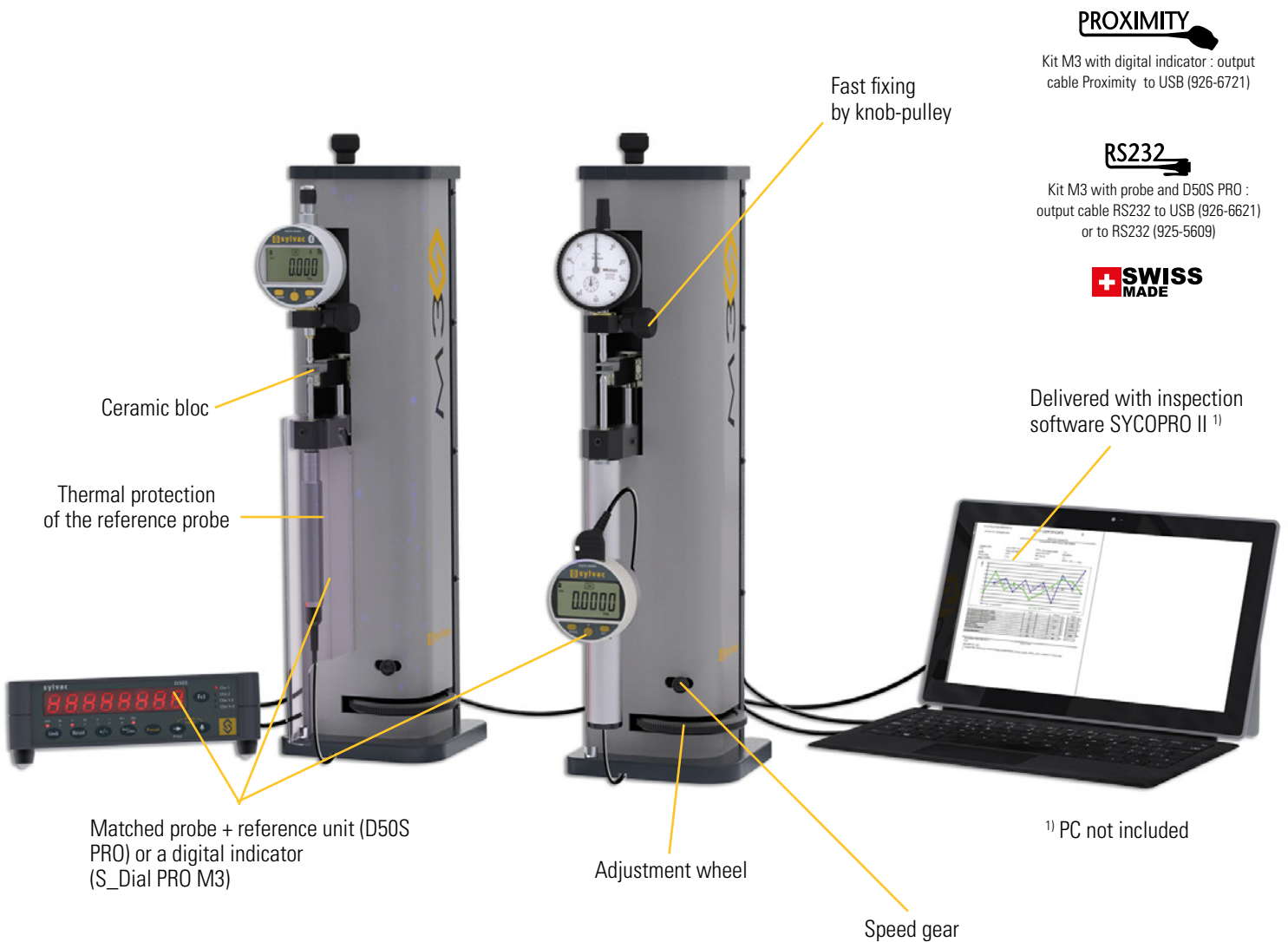

Digital indicator testing stand M3

DISPLAY/SOFTWARE

- 1 Display the curves of measurement
- 2 Check the error and repeatability
- 3 Creation and management of instrument groups
- 4 Fast access to all of stored instruments
- 5 Integrated standards
- 6 Personalisation of the standards
- 7 Display the measured values
- 8 Possibility to customize the certificate

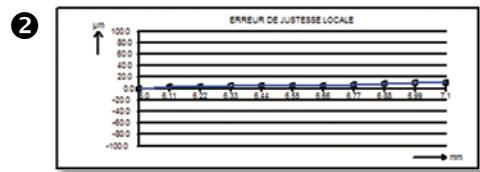
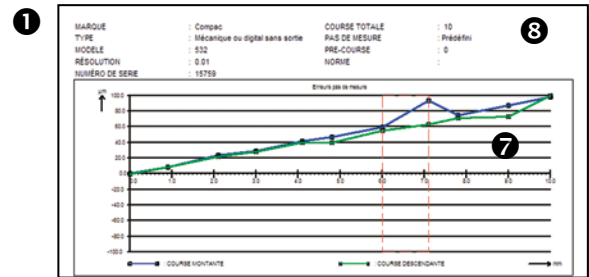

3 Instrument management window showing a list of instruments under the group 'LABORATORY':

- Digital Caliper Sylvac 150mm
- Digital indicator Sylvac 12.5mm - 0.01
- Digital indicator Sylvac 5mm - 0.001
- Digital indicator Sylvac 12.5mm - 0.001
- Digital indicator Sylvac 25mm - 0.001
- Digital indicator Sylvac 25mm - 0.01
- Digital indicator Sylvac 25mm - 0.01

4 Instrument configuration window for 'Nouvelle norme' (New standard) with fields for 'Nom', 'Configuration', 'Erreur', and 'Options d'impression'. It includes checkboxes for 'Erreur justesse', 'Erreur locale', 'Erreur de fidélité', and 'Erreur maximum', along with various dropdown menus and input fields.

5 Normes (Standards) list window showing various standard codes and their corresponding measurement ranges and resolutions.

6 Instrument configuration window for 'Nouvelle norme' showing detailed error settings: 'Erreur justesse', 'Erreur locale', 'Erreur de fidélité', 'Erreur maximum', 'Erreur justesse totale', 'Erreur locale', 'Erreur de fidélité', and 'Erreur hystérésis (s)'. It also includes a 'Fichier classe de précision' field.

TECHNICAL SPECIFICATIONS

		Kit with probe and D50S PRO		Kit with digital indicator	
		809-1303	809-1301	809-1305	809-1304
Measuring range	mm	M3 Kit probe 10 mm	M3 Kit probe 25 mm	M3 Kit S_Dial PRO M3 25 mm	M3 Kit S_Dial PRO M3 50 mm
Max. Error	µm	0.6	0.8	1.0	1.2



Digital indicator testing stand M3

STANDARD DELIVERY

- M3 support
- 3 ceramic shims precision DIN861 Grade 1: 2 x 1.5 mm and 1 x 4 mm
- CD with Sycopro II software and its activation licence
- Accessory 909-2010 for the control of lever indicators
- Calibration certificate

Set with probe and units

- Pair measuring probe with unit D50S Pro
- Charging unit according to country
- External contact (pedal) 904-4101
- RS232 connection cable 925-5609

Set with precision digital indicator

- S_Dial Pro M3 dial gauge with special measuring force
- Proximity-USB connection cable 926-6721
- External USB contact (footswitch) 926-7020

B

ACCESSORIES

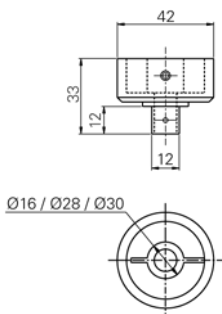
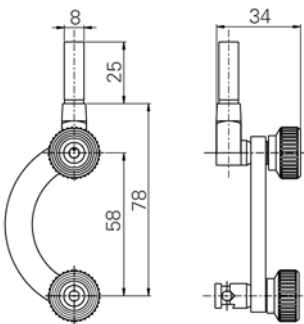

909-2010	Clamping device for test indicator
909-2011	Clamping device for dial gauges Ø 16 / 28 / 30 mm

Measuring stands

DESCRIPTION

Stands with magnetic base for lever indicators

- Imported article
- Vertical rod Ø 16 mm and hinged horizontal rod Ø 12 mm
- Maximum measuring height 350 mm
- Magnetic base with attraction force 80 kg
- Clamping diameter 8 mm

Stands for comparators and probes with ceramic table

- Imported article
- Vertical chrome steel column Ø 25 mm
- Clamping diameter 8 mm
- Maximum measuring height 115 mm
- Cast iron base with ceramic table 85 x 85 x 25 mm, grade xx

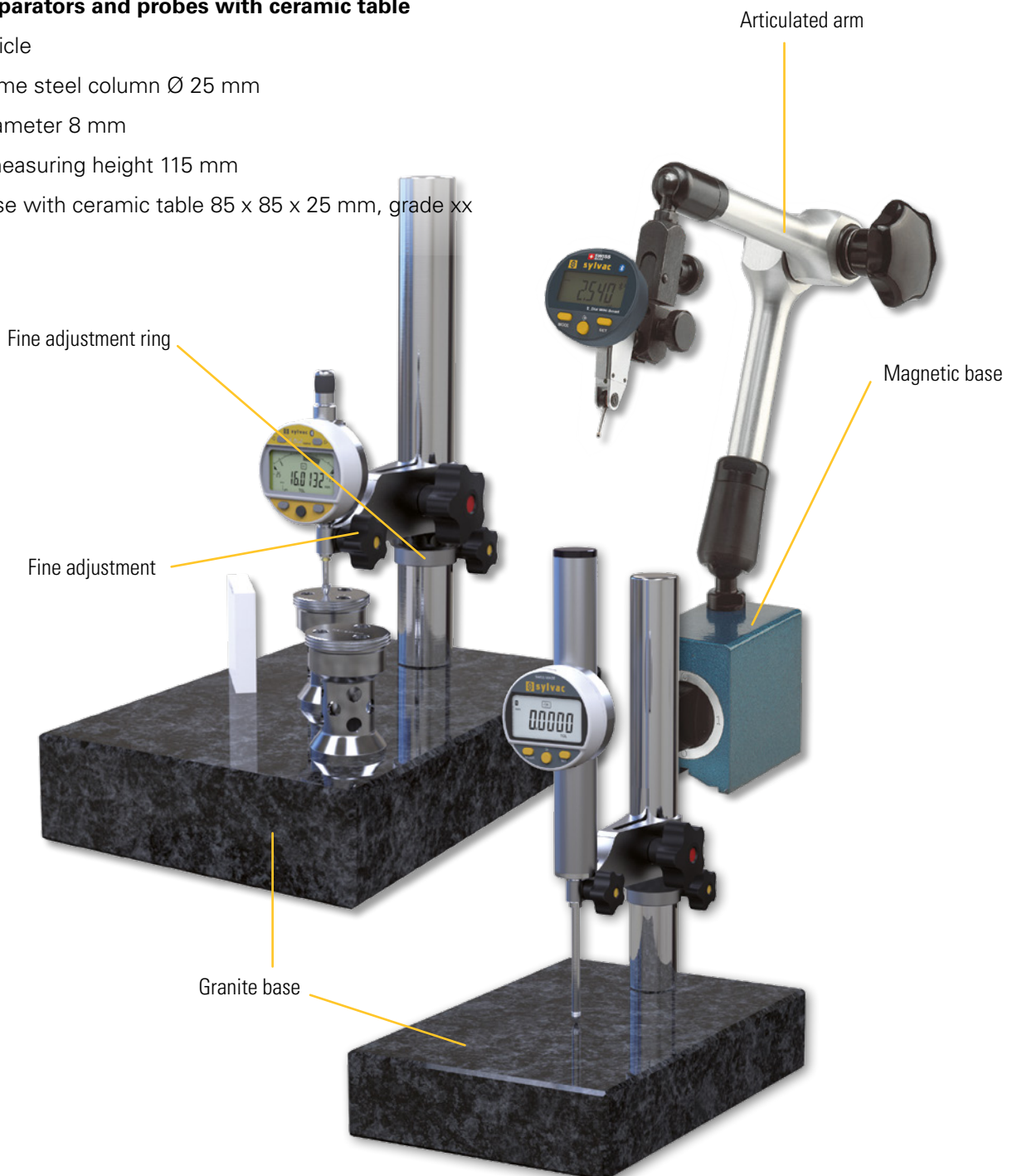



Measuring stands

TECHNICAL SPECIFICATIONS



908-1201

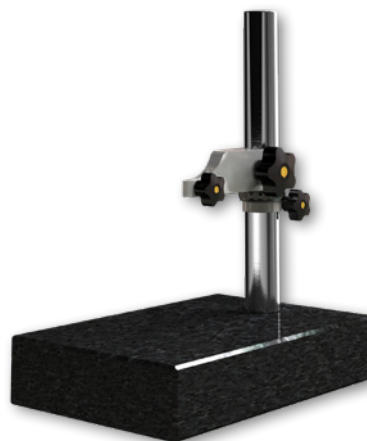

808-1204

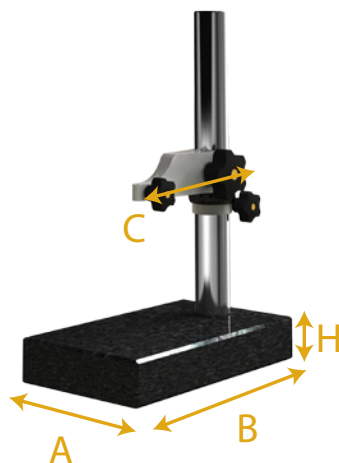

B

		908-1201	808-1204	808-1205
Base		magnetic ¹⁾	granit grade 00	granit grade 00
Base dimensions AxBxH	mm	70x46x65	300x210x60	300x210x60
Central locking		•	---	---
Column	mm	---	Steel Ø 35	Steel Ø 35
Clamping dimension	mm	Ø 8	Ø 8	Ø 25
Dist. Column.-meas. point. C	mm	---	115	115
Measuring range	mm	---	0 - 260	0 - 260
Total height	mm	430	360	360
Weight	kg	2.2	13.4	13.5
Fine adjustment		---	•	•

¹⁾ Gripping coefficient : 600N