



MEASURING BENCH PS15/16/17

Benefiting from long experience acquired through contact with our demanding Swiss watchmaking customers, Sylvac has developed a range of measuring benches enabling most small external and internal dimensions to be checked precisely and quickly.

As the miniaturisation of components nowadays affects all industrial fields, Sylvac is in a position to provide a reliable solution with these instruments for the most unlikely of applications.

GENERAL CHARACTERISTICS :

- **PS15 and PS17 measuring benches to be equipped with a digital indicator or a measuring probe**
- **PS16 V2 measuring benches with integrated display**
- **Powered by lithium battery type CR2477/CR2032 (PS16 V2)**
- **mm/inch conversion on all models**
- **Working temperature +5° to +40°C**



Bench table

PS15

DESCRIPTION

- Horizontal precision bench for measuring small external dimensions
- Can be equipped with either a digital digital indicator or a Sylvac measuring probe.
- Robust cast iron construction
- 2 ergonomic levers for moving the movable axis with ball-bearing guide
- Compatible with Sylvac Ø 1.5 mm and Cary type anvils
- Supplied with hard metal measuring anvils Ø 1.5 mm
- Adjustable measuring force 0.3-1.0 N
- Measuring capacity 20 mm, measuring range 10 mm
- Wide choice of measuring anvils and support tables

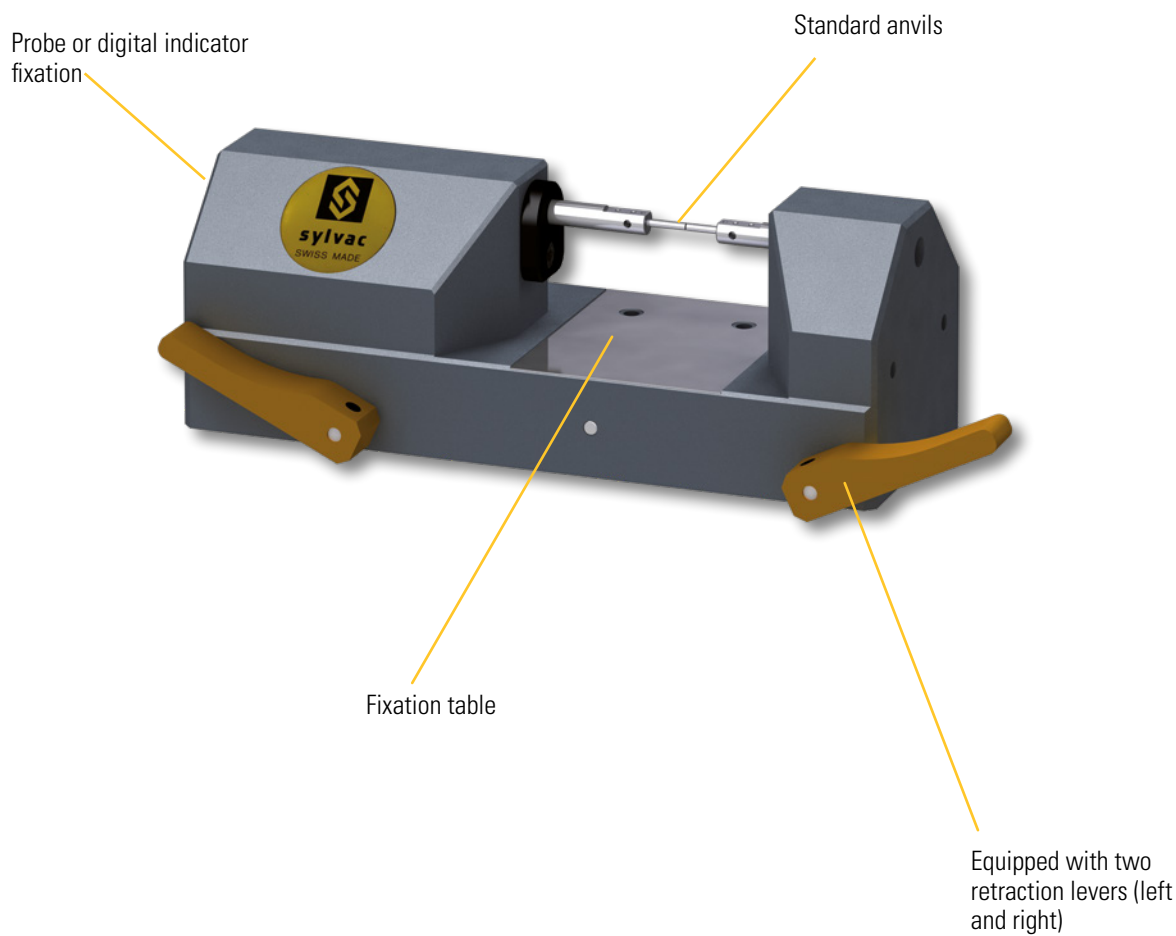

Bench table

PS15

DIMENSIONAL DRAWINGS

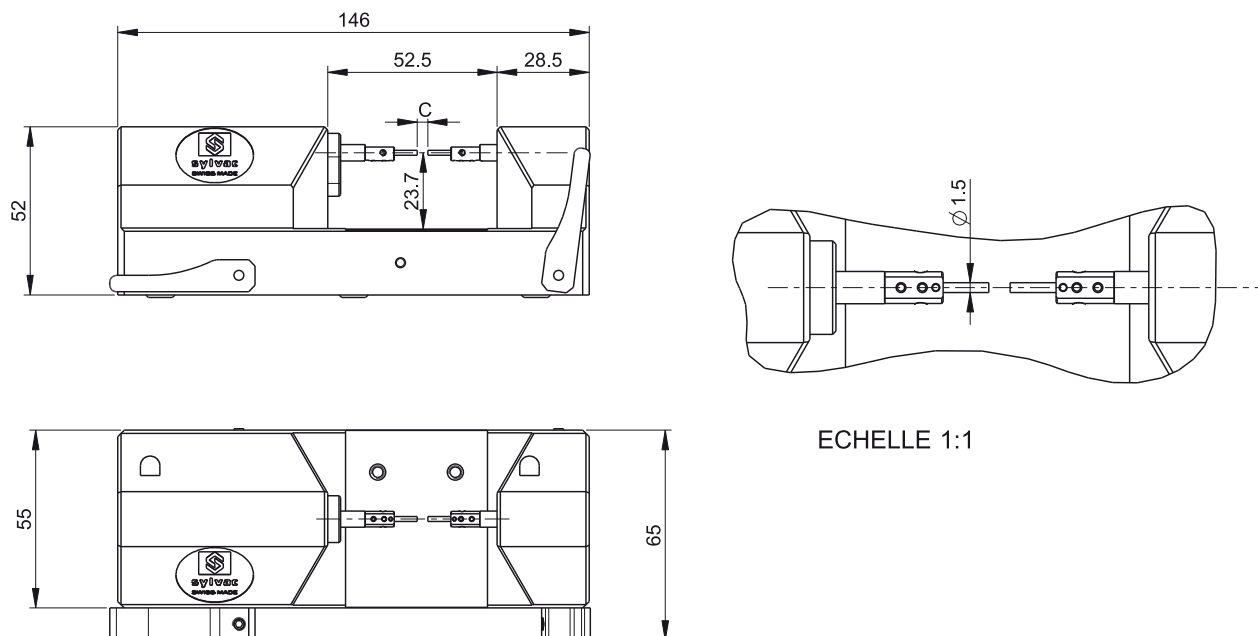

ECHELLE 1:1

TECHNICAL SPECIFICATIONS

		808-1215
Type		PS15BH
Max. Capacity C	mm	20
Measuring range	mm	10
Adjustable measuring force	N	0.3 - 1.0
Max. error	µm	Probe P10 : 0.6µm / Digital indicator S_Dial : 1.6 - 3µm
Weight	kg	1.8
Measuring direction		Horizontal
Anvils fixation		Ø 1.5 mm
Cary Compatibility		•

STANDARD DELIVERY

- Instrument according to technical specifications
- Instruction manual
- Measuring anvils Ø 1.5 mm (908-2175)
- Allen anvils 2 and 2.5 mm
- Dust cover

Bench table

PS15

DESCRIPTION

- Measuring bench similar to the horizontal bench but prepared for vertical use, with support base and levers positioned to the left and right of the bench.
- This bench is generally equipped with either a flat round table 908-2165 or a rotary hole table 908-2172 with 25 bores \varnothing 0.2 to 5 mm for measuring shoulder heights. These tables are to be ordered separately
- Supplied with hard metal measuring anvils \varnothing 1.5 mm

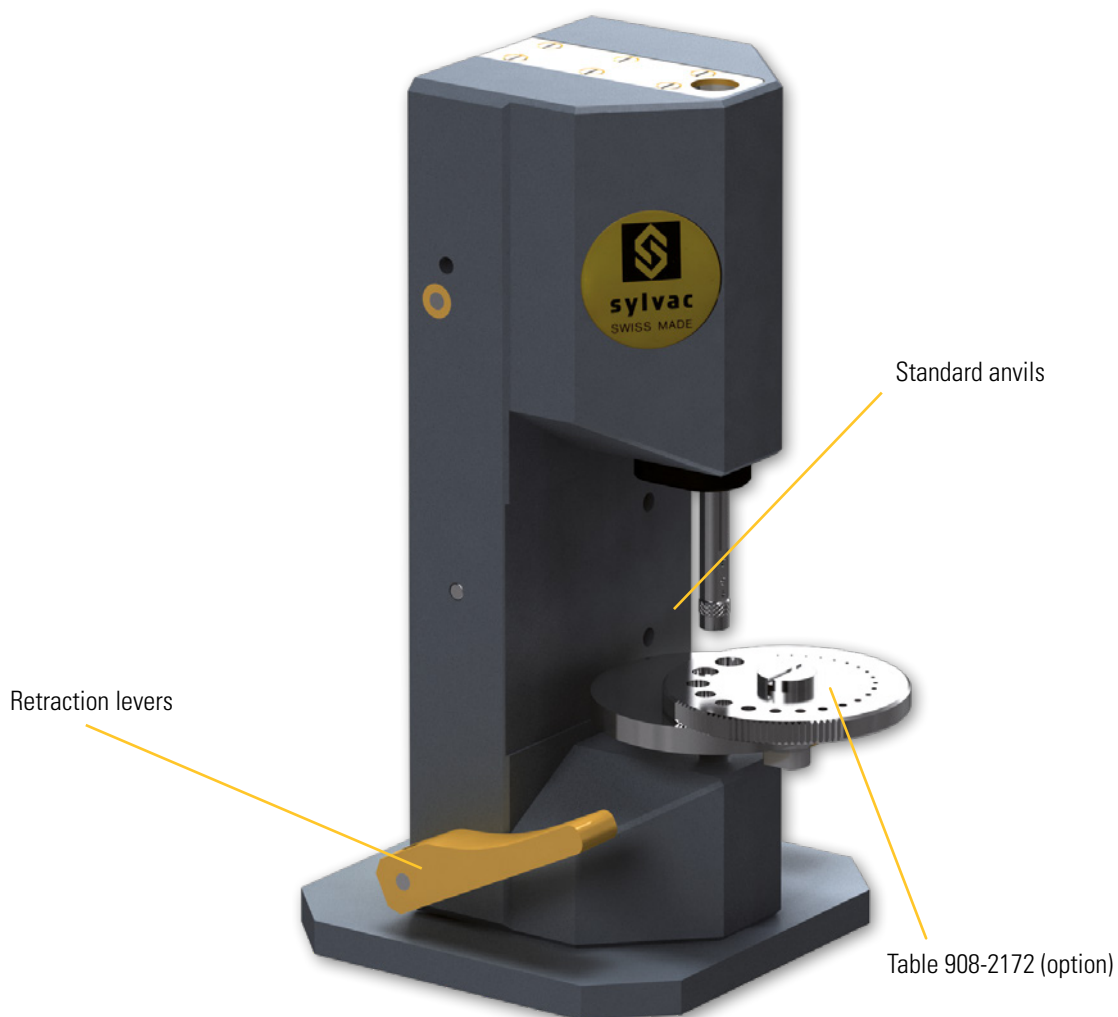

Bench table

PS15

DIMENSIONAL DRAWINGS

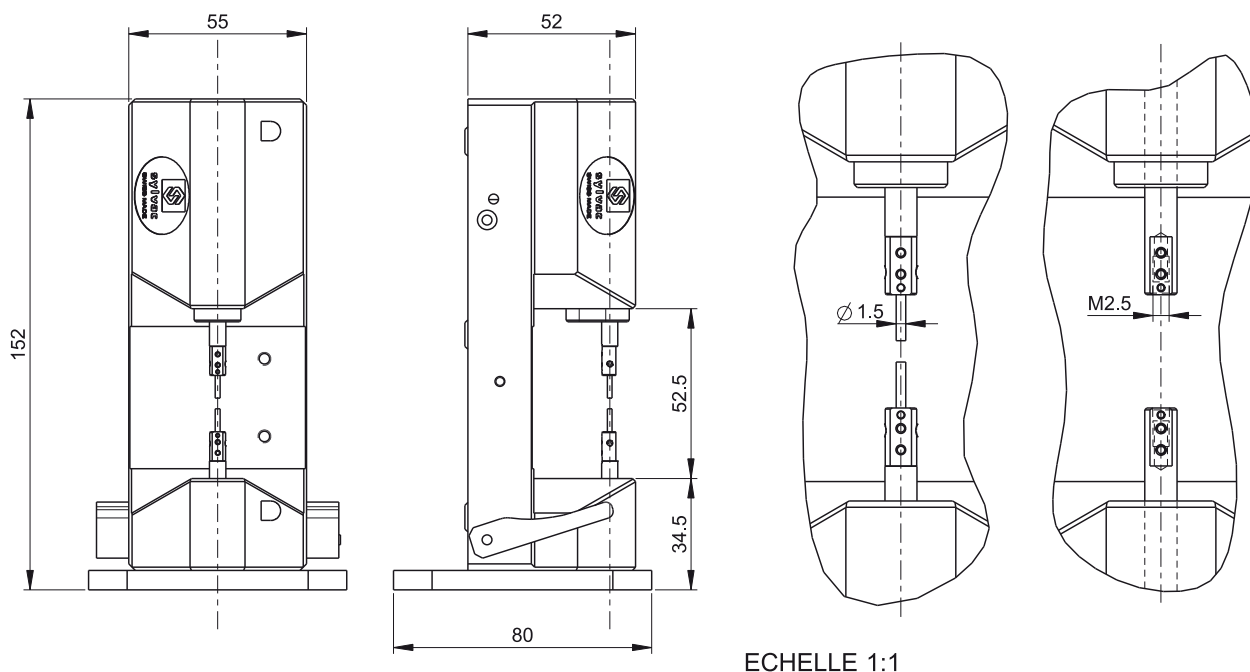

TECHNICAL SPECIFICATIONS

		808-1216	808-1218
Type		PS15BV	PS15BV +
Measuring scale	mm	10	10
Adjustable measuring force	N	0.3 - 1.0	0.3 - 1.0
Max. error	µm	Probe P10 : 0.6µm / Digital indicator S_Dial : 1.6 - 3µm	
Weight	kg	1.8	1.8
Measuring direction		Vertical	Vertical
Anvils fixation		M2.5	Ø 1.5 mm
Cary Compatibility		•	•

STANDARD DELIVERY

- Instrument according to technical specifications
- Instruction manual
- Measuring anvils Ø 1.5 mm or Ø 5 mm (depending on model)
- Allen anvils 2 and 2.5 mm
- Dust cover

Bench table

PS15

TABLES, PLATES AND LAPPING



N°	Designation	PS15BH	PS15BV / BV+
908-2170	Supporting table adjustable in XYZ	•	
908-2160	Supporting table with fine adjustment XYZ	•	
908-2161	Supporting table with fine adjustment Z	•	
908-2166	Floating table	•	
908-2172	Rotating table with 25 bores		•
908-2165	Plain table only		•
908-2162	Cylindrical plate with 25 bores from 0.2 to 5 mm		•

ACCESSORIES



N°	Designation	PS15BH	PS15BV / BV+
908-2198	Replacement lapping stone for 908-2199	•	
908-2199	Lapping device (3 stones and lapping liquid included)	•	

Lapping device

- Device for lapping the anvils on the PS15 BH, PS16 V2 and PS17 measuring benches, enabling perfect parallelism of the anvils for greater measuring accuracy.
- Set consisting of a movable element with linear guide and a motorised rotary drive system for the honing stone
- Delivered complete with 3 honing stones and a bottle of honing liquid.

ANVILS

Compatible anvils list at the end of this chapter.

Bench table

PS15

APPLICATIONS

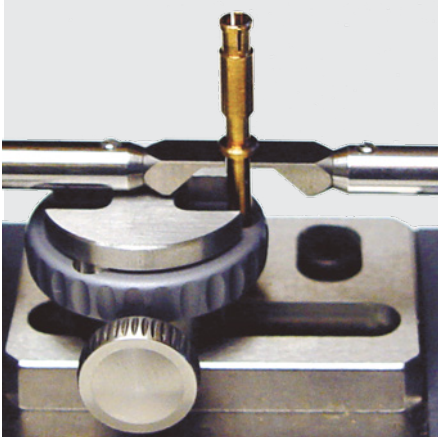

XYZ table with plate with fine adjustment.

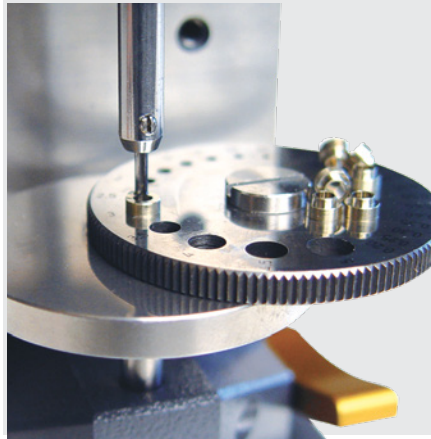

Measurement of small parts with PS15V+ and rotation 25 holes support

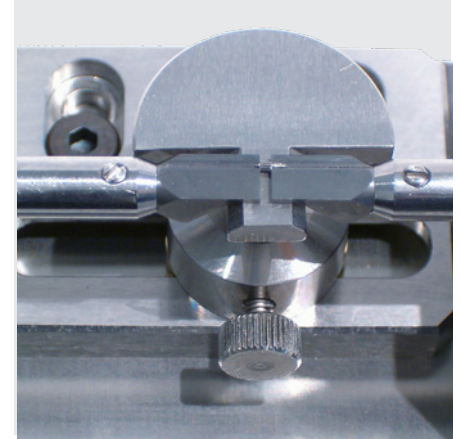

Special anvils

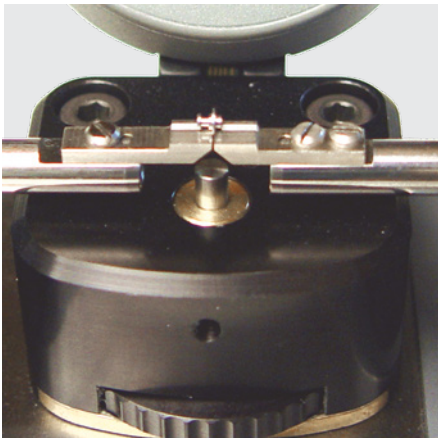
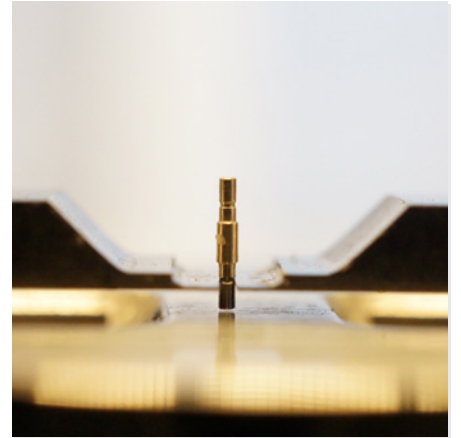

Table with plate \varnothing 3 mm and fine adjustment. Indication of the height integrated.



Multi-functional measuring station



Gear measuring anvils. On request



Bench table

PS16 V2

DESCRIPTION

SMART

- Precision horizontal measuring bench for the measurement of external dimensions
- Robust cast iron construction
- New design with integrated Bluetooth® system
- Large display resolution 0.0001 mm (0.1 µm) with tolerance status indication by colour LEDs
- Three buttons, including the central button with selectable favourite function
- 2 ergonomic, position-adjustable levers for moving the movable axis with ball bearing guide
- The position of the levers can be used to adjust the backward movement of the mobile axis.
- Compatible with Sylvac Ø 1.5 mm and Cary type anvils
- Supplied with hard metal measuring anvils Ø 1.5 mm
- Adjustable measuring force 0.1-0.6 N
- Measuring range 25 and 50 mm
- Additional data outputs Power and Proximity
- Protection class IP67

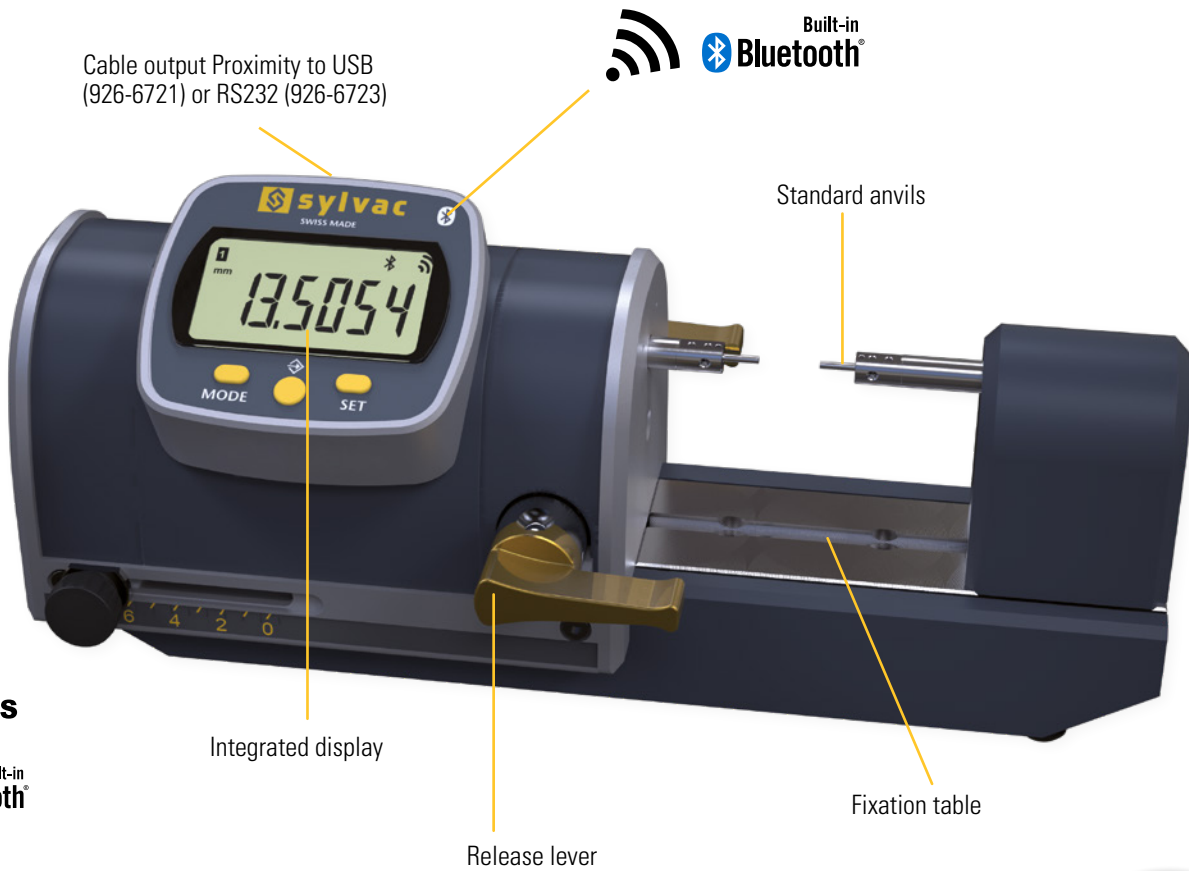

SWISS MADE

Built-in **Bluetooth**

USB

PROXIMITY

WATER RESISTANT

IP67

Cable output mini-USB to USB (926-6001)

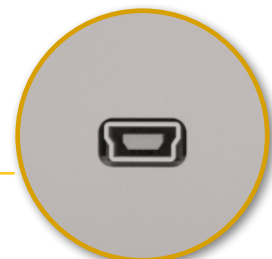

Bench table

PS16 V2

DIMENSIONAL DRAWINGS

SMART

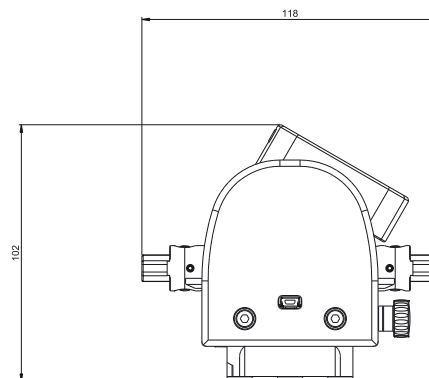
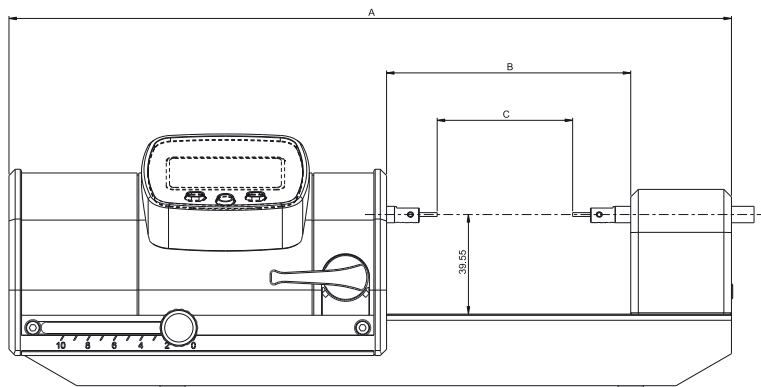

TECHNICAL SPECIFICATIONS

External measurement		808-1231	808-1232
Max. Capacity C	mm	25	50
Max. Error	µm	1.5	2.0
Repeatability	µm	0.2	0.2
Resolution	µm	0.1	0.1
Measuring force (Adjustable)	N	0.1 - 0.6 ¹⁾	
Weight	kg	3.6	4.2
Output data		Bluetooth® wireless technology* / RS232 / USB	
Anvils clamping dimension	mm	Ø 1.5	
Cary compatibility		●	
A	mm	232	287
B	mm	66	97

¹⁾ ± 20%

STANDARD DELIVERY

- Instrument according to technical specifications
- Instruction manual
- Lithium battery CR2477 included
- Adapter for Lithium battery CR2032
- Calibration certificate
- Table not included
- Anvils Ø 1.5mm (908-2175)
- Dust cover

Bench table

PS16 V2 LV

DESCRIPTION

SMART

- Measuring bench similar to the PS16 V2 bench, but equipped with a table and anvils assembly allowing to measure large internal diameters up to 74 mm.
- Originally designed for measuring watch cases, it is also suitable for measuring rings and thin parts.
- 2-point measurement with positioning of the workpiece in the measuring axis by 2 movable centring pins
- Table height adjustable by up to 20 mm (a mini dial indicator can be mounted on the table to check its movement)
- Available in 3 versions :
 - 808-1233: version for measuring internal diameters from 12 to 62 mm
 - 808-1234: execution for measuring internal diameters 24 to 74 mm
 - 808-1235: special version for measuring outside diameters 0 to 50 mm
- Supplied with 0.4 mm thick measuring anvils.



Bench table

PS16 V2 LV

DIMENSIONAL DRAWINGS

SMART

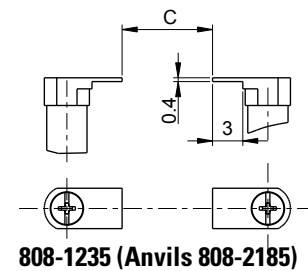
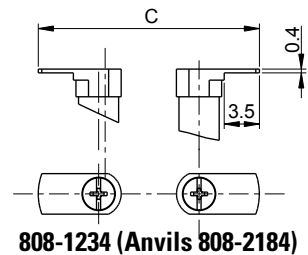
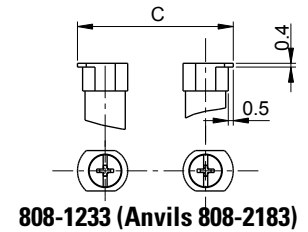
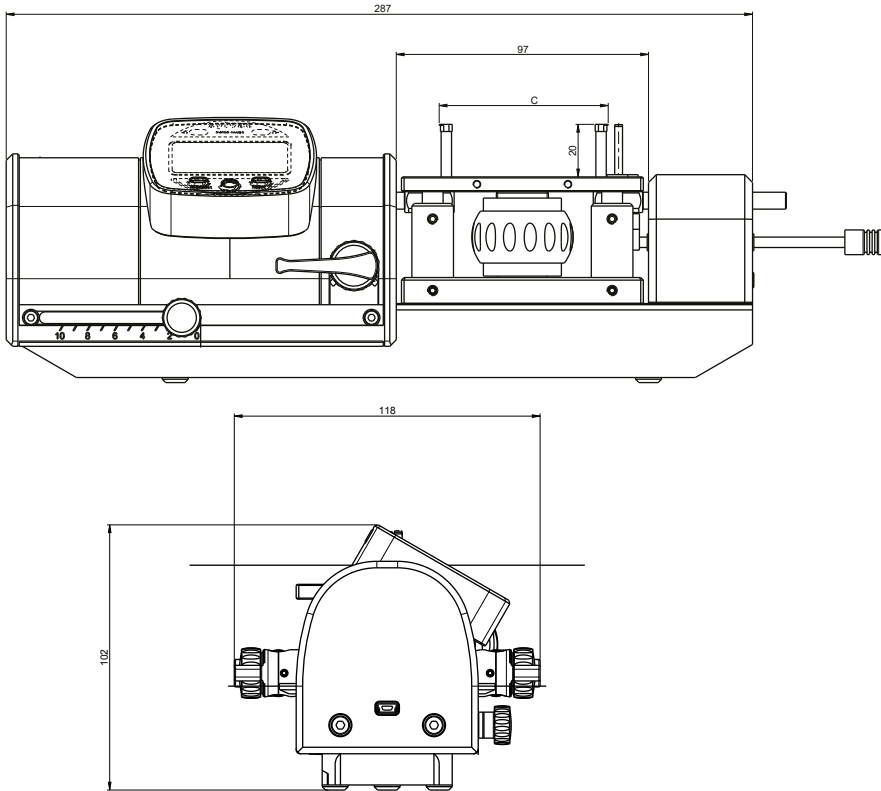

TECHNICAL SPECIFICATIONS

External and internal measurement		808-1233	808-1234	808-1235
Max. Capacity C	mm	Ø 12 - 62	Ø 18 - 68	Ø 0 - 50
Measuring type		Internal measurement		External measurement
Max. Error	µm	6.0	6.0	6.0
Repeatability	µm	1.5	1.5	1.5
Resolution	µm	0.1	0.1	0.1
Measuring force (Adjustable)	N	0.1 - 0.6 ¹⁾		
Weight	kg	5.1	5.1	5.1
Output data		Bluetooth® wireless technology* / RS232 / USB		

¹⁾ ± 20%

STANDARD DELIVERY

- Instrument according to technical specifications
- Lithium battery CR2477 included
- Adapter for Lithium battery CR2032
- Instruction manual
- Calibration certificate
- Anvils 0.4mm and LV table included
- Dust cover

Bench table

PS16 V2 3-Points

DESCRIPTION

SMART

- Measuring bench similar to the PS16 V2 bench, but equipped with a table and anvils assembly allowing very small shallow internal diameters to be measured at 3 points, thanks to an electronic calculation function.
- Calibration using 2 rings supplied with the bench
- Table with fine height adjustment up to 3 mm with mini digital indicator for precise movement control
- Available in 5 versions :
 - 808-1335: version for measuring internal diameters 0.8 to 1.3 mm
 - 808-1336: execution for measuring internal diameters 1.3 to 2.5 mm
 - 808-1337: execution for measuring internal diameters 2.5 to 4 mm
 - 808-1338: execution for measuring internal diameters 4 to 8 mm
 - 808-1339: execution for measuring internal diameters 8 to 12.5 mm
- It is possible to obtain the placemats and anvils separately and to change them according to the dimensions to be measured, but this delicate operation requires a certain amount of dexterity.

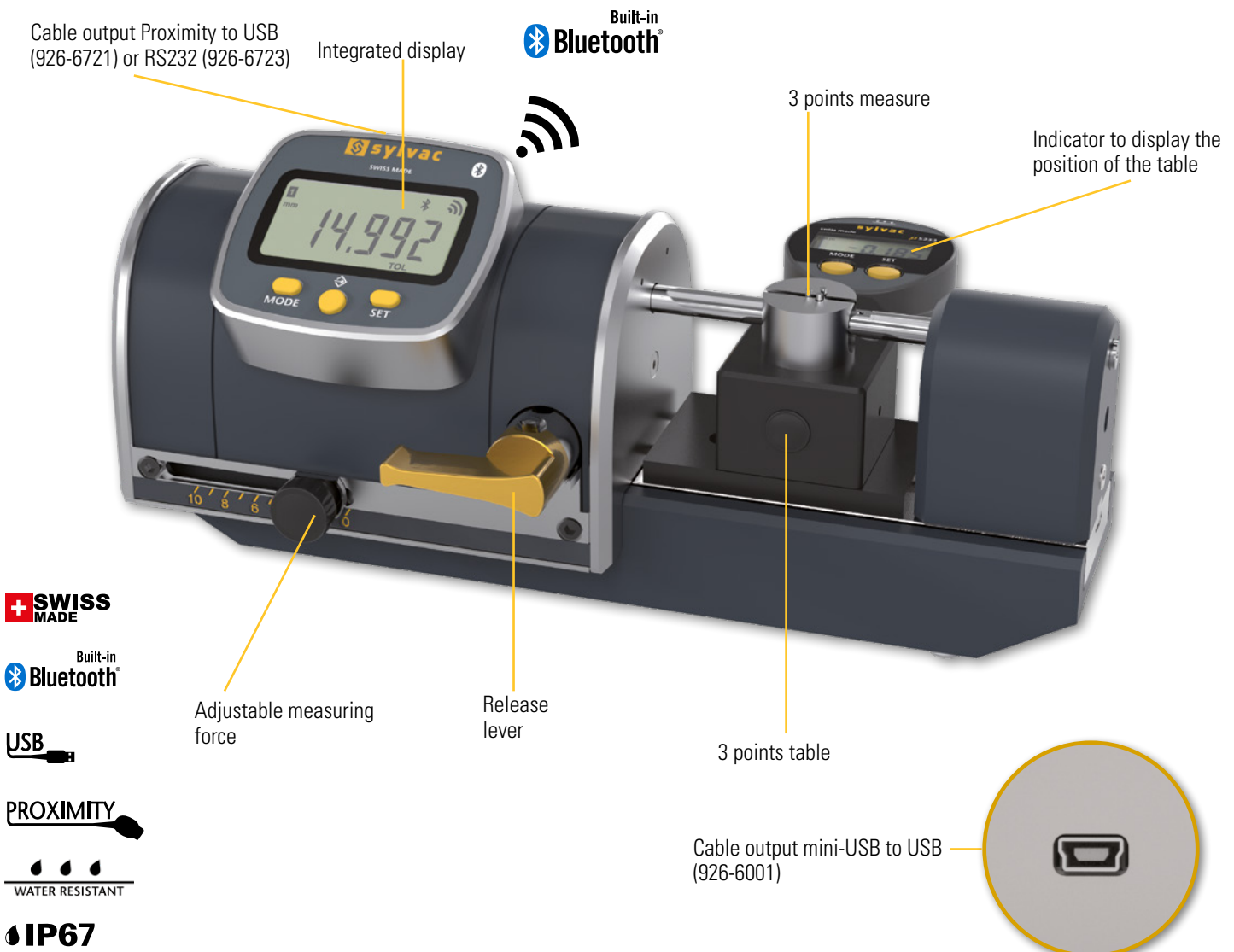

Bench table

PS16 V2 3-Points

DIMENSIONAL DRAWINGS

SMART

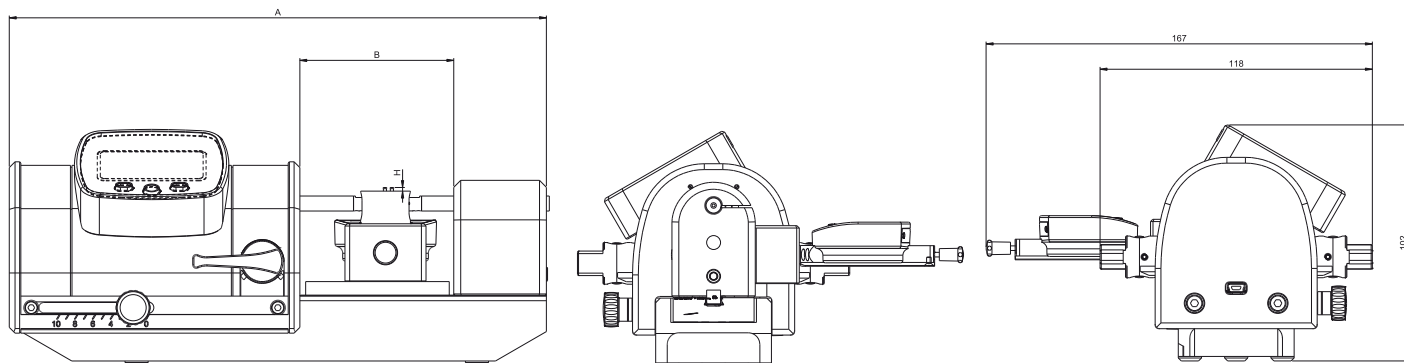

TECHNICAL SPECIFICATIONS

Internal measurement		808-1335	808-1336	808-1337	808-1338	808-1339
Max. Capacity C	mm	Ø0.8-1.3	Ø1.3-2.5	Ø2.5-4.0	Ø4.0-8.0	Ø8.0-12.5
Max. Error	µm	1.5				
Repeatability	µm	1				
Resolution	µm	0.1				
Measuring force (Adjustable)	N	0.1 - 0.6 ¹⁾				
Weight	kg	4.1				
Data output		Bluetooth® wireless technology* / RS232 / USB				
Anvils clamping dimension	mm	Ø1.5				
A	mm	232				
B	mm	60				

¹⁾ ± 20%

STANDARD DELIVERY

- Instrument according to technical specifications
- Lithium battery CR2477 included
- Adapter for Lithium battery CR2032
- Instruction manual
- Calibration certificate
- Table and anvils according to technical specification
- Mini indicator and 2 setting rings included
- Dust cover

Bench table

PS16 V2 Goutte

DESCRIPTION

SMART

- Measuring bench similar to the PS16 V2 bench but equipped with a table and anvils set specially designed to measure small pivots (called drops in the watch industry) on watch plates.
- Equipped with height-adjustable table, quick-release lever and key removal system
- Delivered complete and ready to use for this particular application

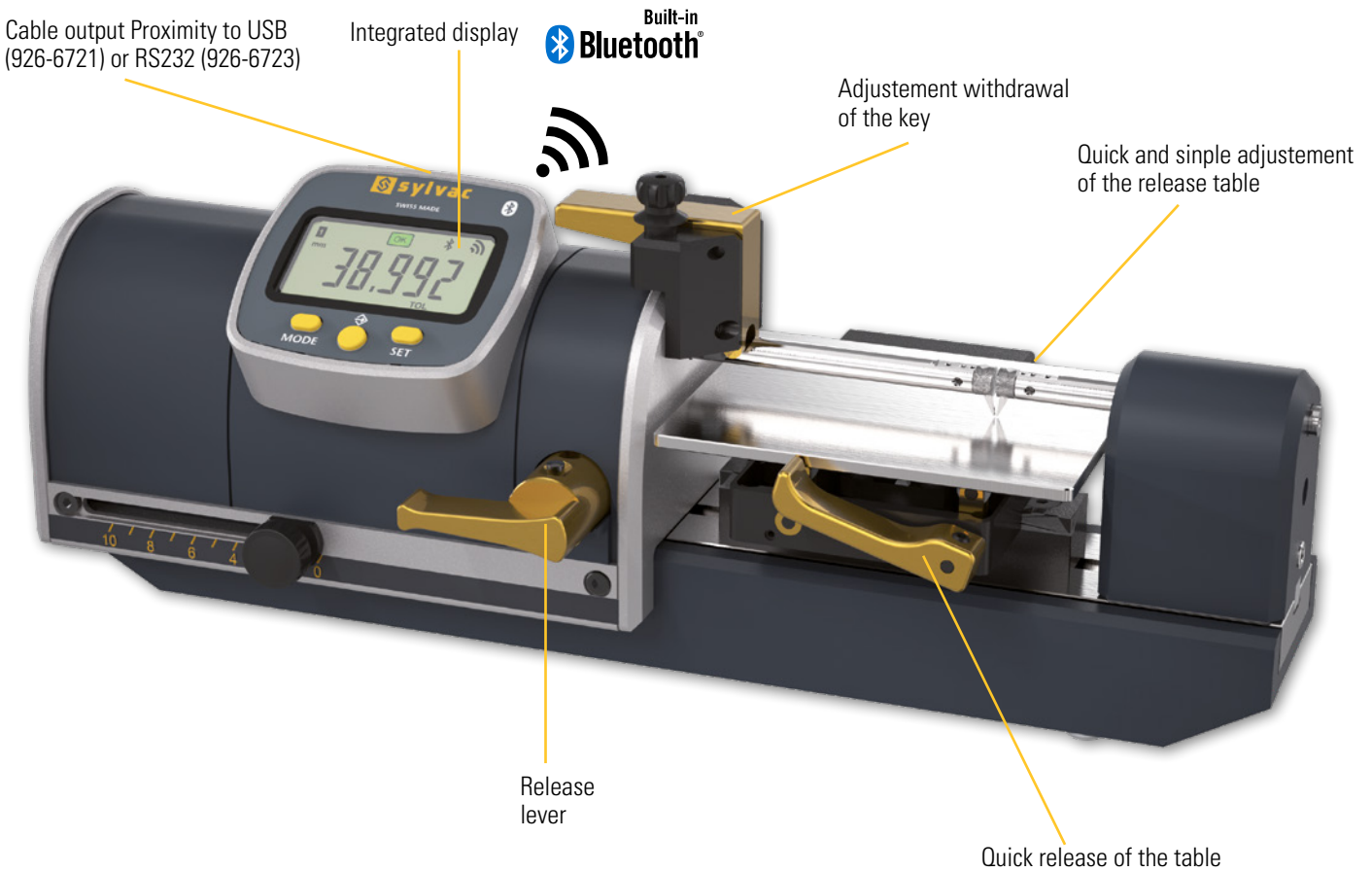

SWISS MADE

Built-in **Bluetooth**

USB

PROXIMITY

WATER RESISTANT

IP67

Cable output mini-USB to USB (926-6001)



Bench table

PS16 V2 Goutte

DIMENSIONAL DRAWINGS

SMART

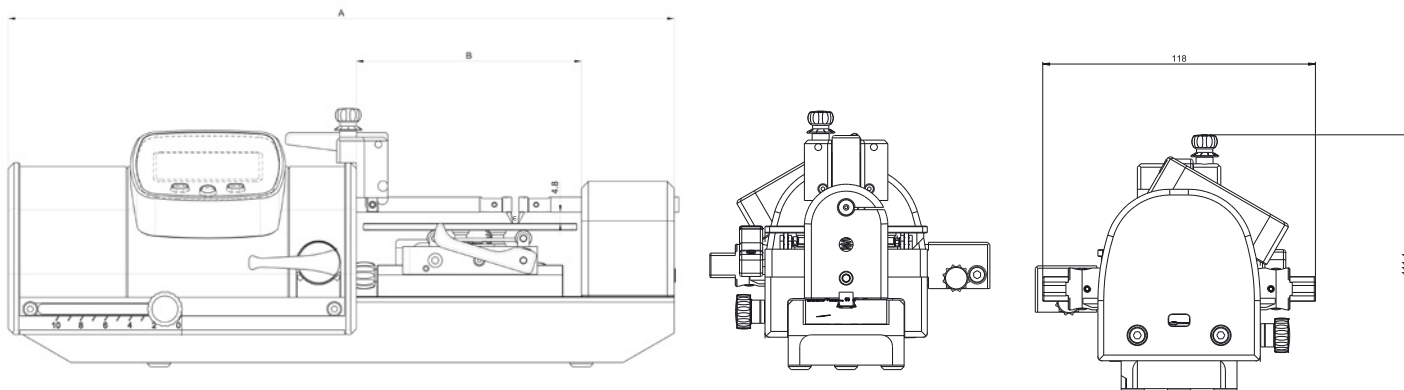

TECHNICAL SPECIFICATIONS

External measurement		808-5213	808-5413
Max. Capacity C	mm	25	50
Quick clearance	mm	7	7
Measuring range E	mm	3	3
Resolution	µm	0.1	0.1
Max. Error	µm	2.5	3.5
Repeatability	µm	0.5	0.5
Table dimensions (lxL)	mm	58x70	92x70
Measuring force (Adjustable)	N	0.1 - 0.6 ¹⁾	
Weight	kg	4.0	4.7
Output data		Bluetooth® wireless technology* / RS232 / USB	
A	mm	232	287
B	mm	66	97

¹⁾ ± 20%

STANDARD DELIVERY

- Instrument according to technical specifications
- Lithium battery CR2477 included
- Adapter for Lithium battery CR2032
- Instruction manual
- Calibration certificate
- Table and anvils according to specification
- Dust cover

Bench table

PS16 V2

TABLES, PLATES AND LAPPING



N°	Designation	PS16 V2 25	PS16 V2 50	PS16 V2 LV	3 points	Goutte
808-2190	Supporting table XYZ	•	•			
808-2302	Supporting table adjustable XZ	•	•			

ACCESSORIES



N°	Designation	PS16 V2 25	PS16 V2 50	PS16 V2 LV	3 points	Goutte
908-2194	Digital indicator holder (display height / depth)			•		
908-2198	Replacement lapping stone for 908-2199	•	•			•
908-2199	Lapping device (3 stones and lapping liquid included)	•	•			•
808-2196	Setting ring Ø20mm			•		
808-2197	Setting ring Ø30mm			•		

Lapping device

- Device for lapping the anvils on the PS15 BH, PS16 V2 and PS17 measuring benches, enabling perfect parallelism of the anvils for greater measuring accuracy.
- Set consisting of a movable element with linear guide and a motorised rotary drive system for the honing stone
- Delivered complete with 3 honing stones and a bottle of honing liquid.

ANVILS

Compatible anvils list at the end of this chapter.

Bench table

PS16 V2

APPLICATIONS

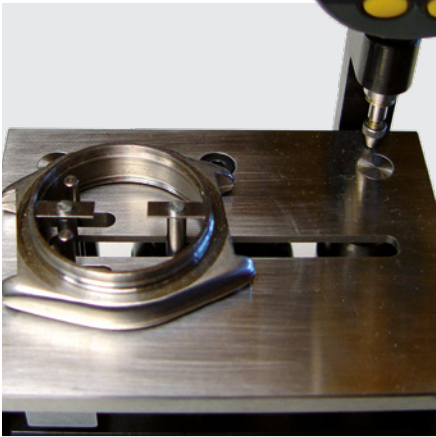

Internal measurement in 2 – points with auto-centering of the part on LVS 50

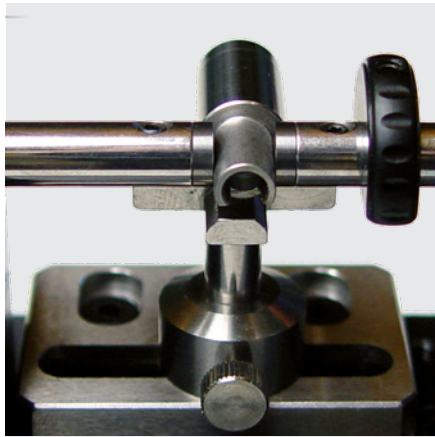

External measurement with anvils \varnothing 6.5 and XYZ table

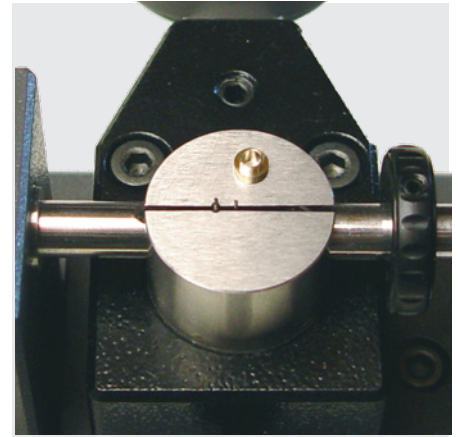

Table and anvils for internal measurement in 3 - points 1.3 - 2.5 mm

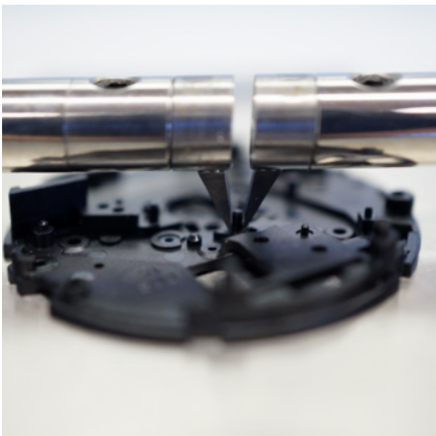
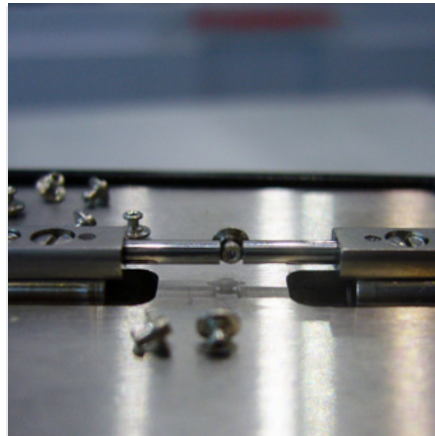

Table with adjustable plate (height). Different \varnothing plates available



Measurement of a small external diameter

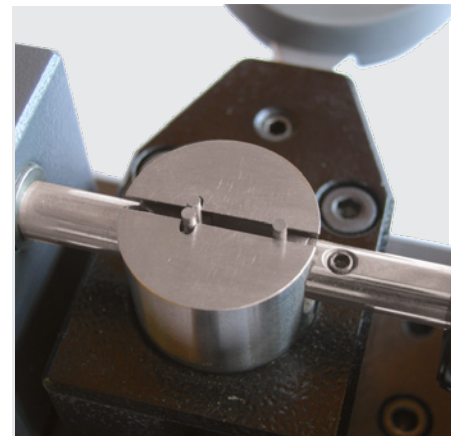

Table and anvils for internal measurement in 3 - points 2.5 - 4 mm



Bench table

PS17 VS

DESCRIPTION

- Horizontal precision bench for measuring small external dimensions similar to the PS15 bench, but with a tailstock.
- Can be equipped with either a digital digital indicator or a Sylvac measuring probe.
- Robust cast iron construction
- 2 ergonomic levers for moving the movable axis with ball-bearing guide
- Equipped with a micrometric screw to control the recoil of the mobile axis.
- Compatible with Sylvac \varnothing 1.5 mm and Cary type anvils
- Supplied with hard metal measuring anvils \varnothing 1.5 mm
- Adjustable measuring force 0.2-1.0 N
- Measuring capacity 37 mm, measuring range 10 mm

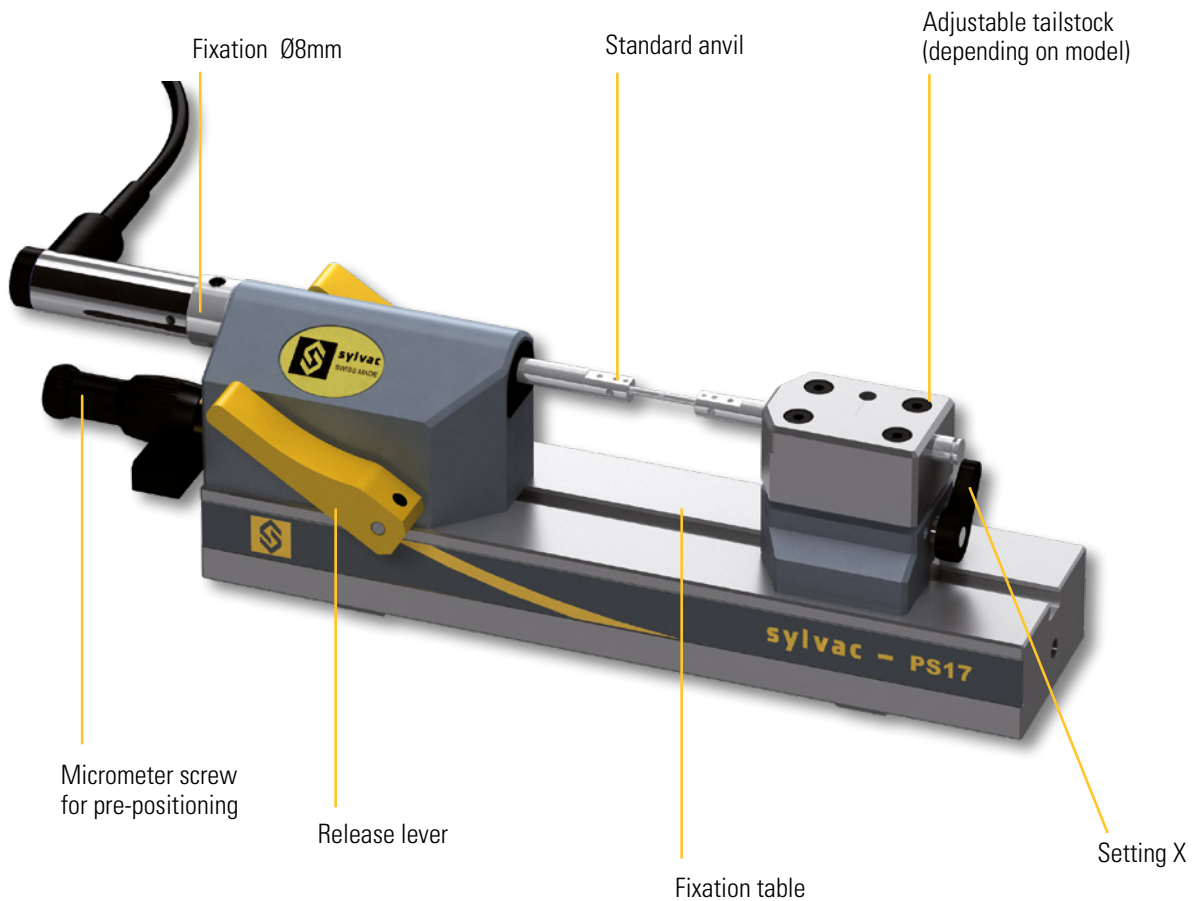

Bench table

PS17 VS

DIMENSIONAL DRAWING

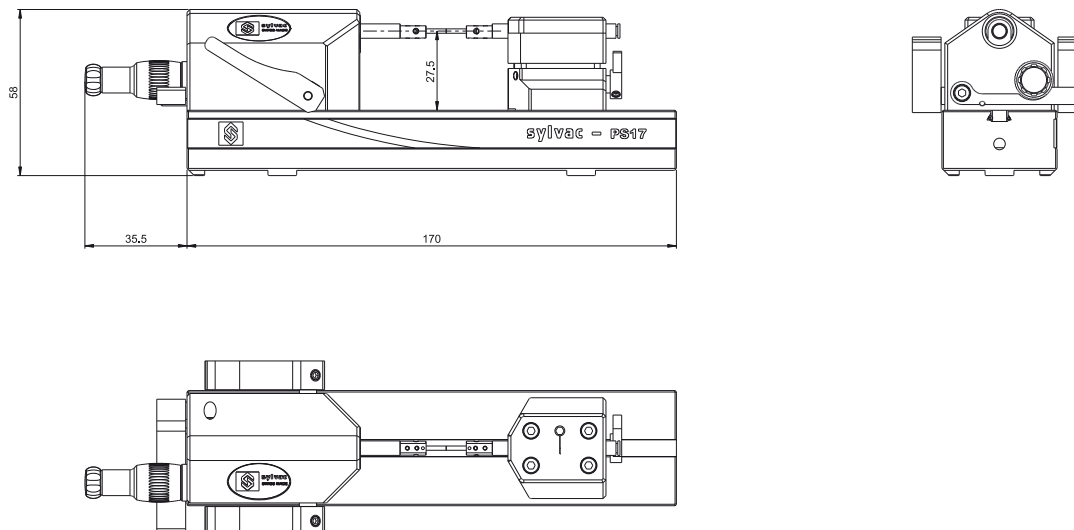

TECHNICAL SPECIFICATIONS

		908-1242
Type		VS ¹⁾
Measuring system		at choice ²⁾
Tailstock adjustable in Z	± 1.75 mm	•
Measurement capacity C	mm	37
Measuring scale	mm	10
Adjustable measuring force	N	0.2 - 1.0
Weight	kg	1.4
Clamping anvils	$\varnothing 1.5$ mm	•
Compatibility with Cary		•
Micrometer screw		•

STANDARD DELIVERY

- Instrument according to technical specifications
- Instruction manual
- Measuring anvils $\varnothing 1.5$ mm (908-2175)
- Dust cover

Bench table

PS17 Entre-portée

DESCRIPTION

- Measuring bench with great flexibility of use for external dimensions
- Tailstock adjustable in X axis and in Z
- Mini indicator to display the position in Z axis (height) of the tailstock
- Delivered with carbide anvils 0.7mm with 90°V for the measure of distance width
- Accurate micrometer screw for pre-positioning
- Compatibility with Sylvac anvils (Ø1.5mm) and Cary type anvils
- Several accessories available

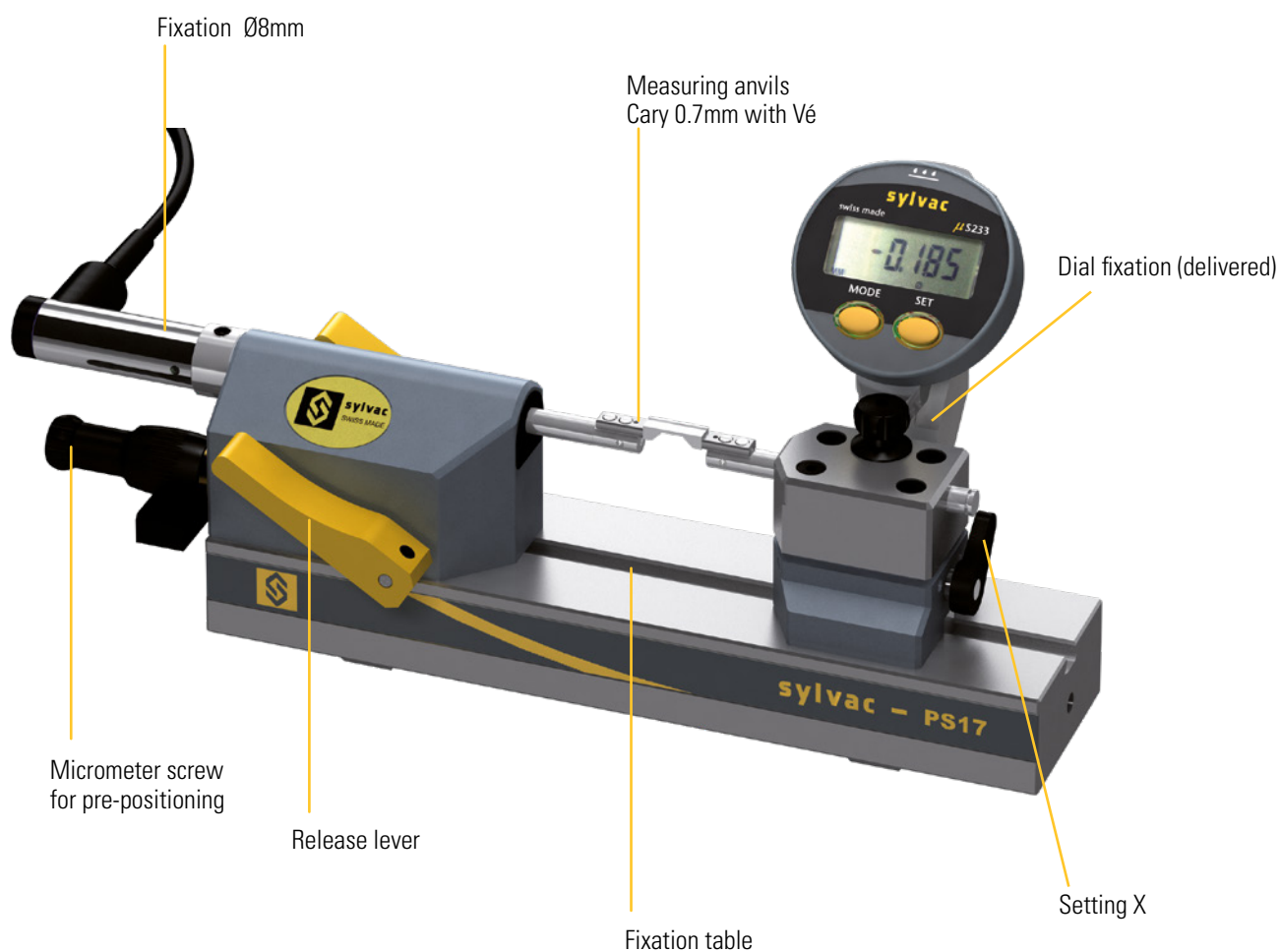

Bench table

PS17 Entre-portée

DIMENSIONAL DRAWINGS

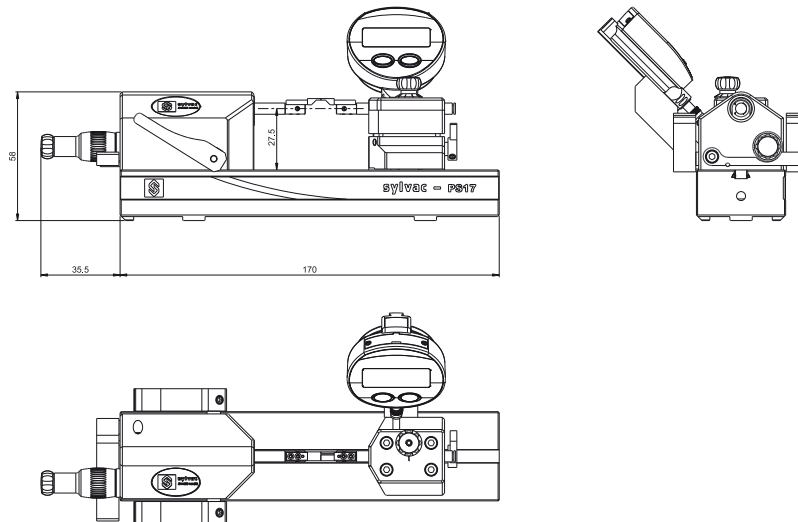

TECHNICAL SPECIFICATIONS

		908-1244
Type		VS
Measuring system		at choice ¹⁾
Tailstock adjustable in Z	±1.75 mm	•
Measurement capacity C	mm	0 - 37
Measurement scale	mm	0 - 10
Measurement force	N	1
Working temperature (storage)	°C	5 - 40 (-10 - 60)
Weight	kg	1.4
Cary Compatibility		•
Micrometer screw		•

¹⁾ No-included on delivery

STANDARD DELIVERY

- Instrument according to technical specifications
- Instruction manual
- Measuring anvils Cary 0.7mm with Vé (908-2220)
- Mini digital indicator
- Dust cover



Bench table

PS17

TABLES, PLATES AND LAPPING



N°	Designation	PS17 VS / VP
908-2290	Supporting table adjustable XYZ	•
908-2301	Supporting table adjustable XZ	•
908-2296	Floating table	•

ACCESSORIES



N°	Designation	PS17 VS / VP
908-2310	Kit for low and strong measuring force	•
908-2198	Replacement lapping stone for 908-2199	•
908-2199	Lapping device (3 stones and lapping liquid included)	•

Lapping device

- Device for lapping the anvils on the PS15 BH, PS16 V2 and PS17 measuring benches, enabling perfect parallelism of the anvils for greater measuring accuracy.
- Set consisting of a movable element with linear guide and a motorised rotary drive system for the honing stone
- Delivered complete with 3 honing stones and a bottle of honing liquid.

ANVILS

Compatible anvils list at the end of this chapter.

Bench table

PS17

APPLICATIONS STANDARD

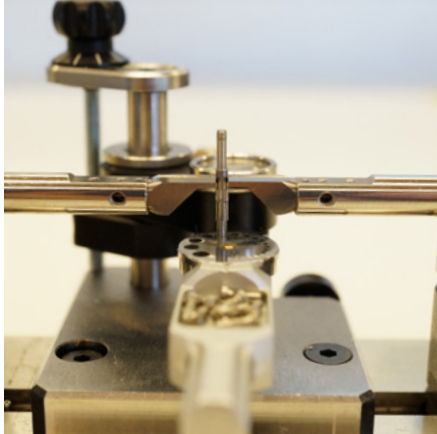

Measure of a small part on a floating table

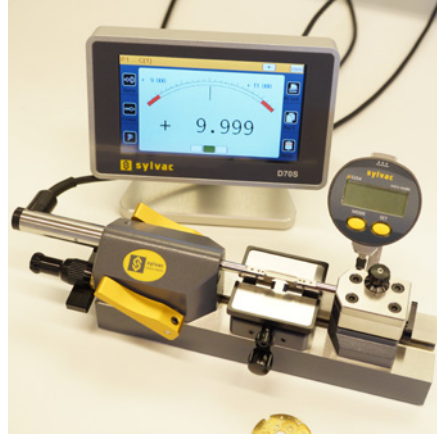

Multifunctional control station

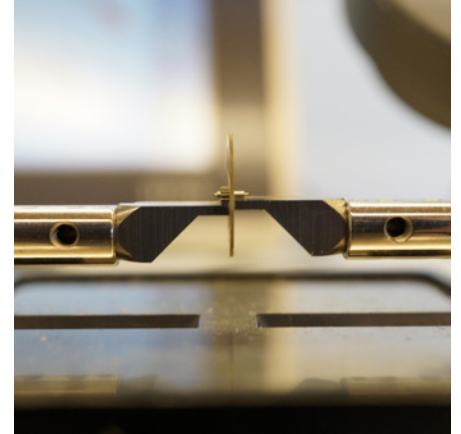

Measure of a distance width with the Z axis adjustable tailstock.





Bench table

PS15/PS16/PS17

ANVILS

Anvils Ø1.5

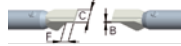
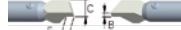
		B	F	C	PS15 BH	PS15 BV	PS15 BV+	PS16 V2	PS16 V2 LV	PS 17
N°	Designation									
	908-2175 Cylindrical anvils TC Ø 1.5 mm	-	8	Ø 1.5	●		●	●		●
	908-2176 Cylindrical anvils TC Ø 2 mm	-	8	Ø 2	●		●	●		●
	908-2177 Cylindrical anvils TC Ø 6.5 mm	-	2	Ø 6.5				●		
	908-2174 Knife-shaped anvils TC 0.7 mm	0.70	2.2	4	●		●	●		●
	908-2178 Knife-shaped anvils TC 0.4 mm	0.40	2.2	4	●		●	●		●
	908-2179 Knife-shaped anvils TC 0.3 mm	0.30	2.2	4	●		●	●		●
	908-2180 Knife-shaped anvils standard TC 0.2 mm	0.20	2.2	4	●		●	●		●
	908-2181 Knife-shaped anvils standard TC 0.14 mm	0.14	2.2	4	●		●			●
	908-2182 Knife-shaped anvils standard TC 0.1 mm	0.10	2.2	4	●		●			●
	908-2201 Knife-shaped anvils TC 0.7 mm/V	0.70	2.2	4	●		●	●		●
	908-2202 Knife-shaped anvils standard TC 1.5 mm	1.5	2.2	4	●		●	●		●

Bench table

PS15/PS16/PS17

ANVILS

Anvils Cary

		B	F	C	PS15 BH	PS15 BV	PS15 BV+	PS16 V2	PS 17
N°	Designation								
	908-2214	Knife-shaped anvils TC 0.10 mm	0.10	2.2	4	●			●
	908-2221	Knife-shaped anvils TC 0.12 mm	0.12	2.2	4	●			●
	908-2215	Knife-shaped anvils TC 0.14 mm	0.14	2.2	4	●			●
	908-2213	Knife-shaped anvils TC 0.15 mm	0.15	2.2	4	●		●	●
	908-2216	Knife-shaped anvils TC 0.20 mm	0.20	2.2	4	●		●	●
	908-2217	Knife-shaped anvils TC 0.30 mm	0.30	2.2	4	●		●	●
	908-2218	Knife-shaped anvils TC 0.40 mm	0.40	2.2	4	●		●	●
	908-2219	Knife-shaped anvils TC 0.70 mm	0.70	2.2	4	●		●	●
	908-2220	Knife-shaped anvils TC 0.70 mm/vé	0.70	2.2	4	●		●	●
	908-2223	Knife-shaped anvils TC 1.5 mm	-	6	Ø1.5	●		●	●
	908-2224	Cylindrical anvils TC Ø 1.5 mm	-	6	Ø2	●		●	●
	908-2225	Cylindrical anvils TC Ø 2.0 mm	-	6	Ø3	●		●	●
	908-2222	Cylindrical anvils TC Ø 3.0 mm	1.50	2.2	4	●		●	●